



PRODUCT

USE INSTRUCTIONS



[Technical support]

Ordering code: 006B31

Part number: FNI ECT-506-105-M

FNI ECT-506-105-M

8xIO-Link,16 DI/8 DO PNP

IO-Link master module user manual



Contents

Security	4
■ Expected use	4
■ Installation and start-up	4
■ Corrosion resistance	4
■ Dangerous voltage	4
■ General security	5
1 Getting started guide	6
1.1 Module overview	6
1.2 Mechanical connection	7
1.3 Electrical connections	7
1.3.1 Power interface (L-code)	7
1.3.2 Network Interface (D-code)	8
1.3.3 I/O-port (A-code)	8
1.3.4 Master module wiring method	10
2 Technical data	11
2.1. Size	11
2.2 Mechanical data	11
2.3 Operating conditions	11
2.4 Electrical data	11
2.5 Network port	12
2.6 Function indicator	12
2.7 EtherCAT node address setting	14
3 Integrated	14
3.1 PLC integration	15
3.1.1 Omron NX1P2 integrated in Sysmac Studio	15
3.1.2 Integrated in BECKHOFF winCATXAE	21
3.1.2 Integrated in Inovance AM600-CPU1608TP/TN	27
4 Appendix	30
4.1 Materials included	30
4.2 Order code	30
4.3 Ordering information	30

■ Expected use

This manual describes as decentralized input and output modules for connecting to an industrial network.

■ Installation and start-up

Precautions!

Installation and start-up may only be performed by trained personnel. A qualified individual is one who is familiar with the installation and operation of the product and has the necessary qualifications to perform such operations. Any damage caused by unauthorized operation or illegal and improper use is not covered by the manufacturer's warranty. The equipment operator is responsible for ensuring that appropriate safety and accident prevention regulations are observed.

■ Corrosion resistance

Precautions!

FNI modules generally have good chemical and oil resistance. When used in corrosive media (e.g. high concentrations of chemicals, oils, lubricants, coolants and other material media (i.e. very low water content), these media must be checked before the corresponding application material compatibility. If a module fails or is damaged due to this corrosive medium, a defect claim cannot be made.

■ Dangerous voltage

Precautions!

Disconnect all power before using the device!

■ General security

Debugging and inspection	Fault	Owner/operator obligations	Expected use
<p>Before debugging, read the user manual carefully.</p>	<p>If the defect or equipment failure cannot be corrected, the operation of the equipment must be stopped to avoid damage that may be caused by unauthorized use.</p>	<p>This equipment is an EMC Class A compliant product. This device produces RF noise.</p>	<p>The warranty and limited liability statement provided by the manufacturer does not cover damage caused by:</p> <ul style="list-style-type: none"> ·Unauthorized tampering ·Improper use operation <p>·The instructions provided in the user manual explain the use, installation and handling of discrepancies</p>
<p>This system cannot be used in an environment where the safety of personnel depends on the functionality of the equipment.</p>	<p>Only after the housing is fully installed can the intended use be assured.</p>	<p>The owner/operator must take appropriate precautions to use this equipment.</p> <p>This device can only use the power supply that matches this device, and can only connect cables approved for application.</p>	

1. Getting Started Guide

1.1 Module overview

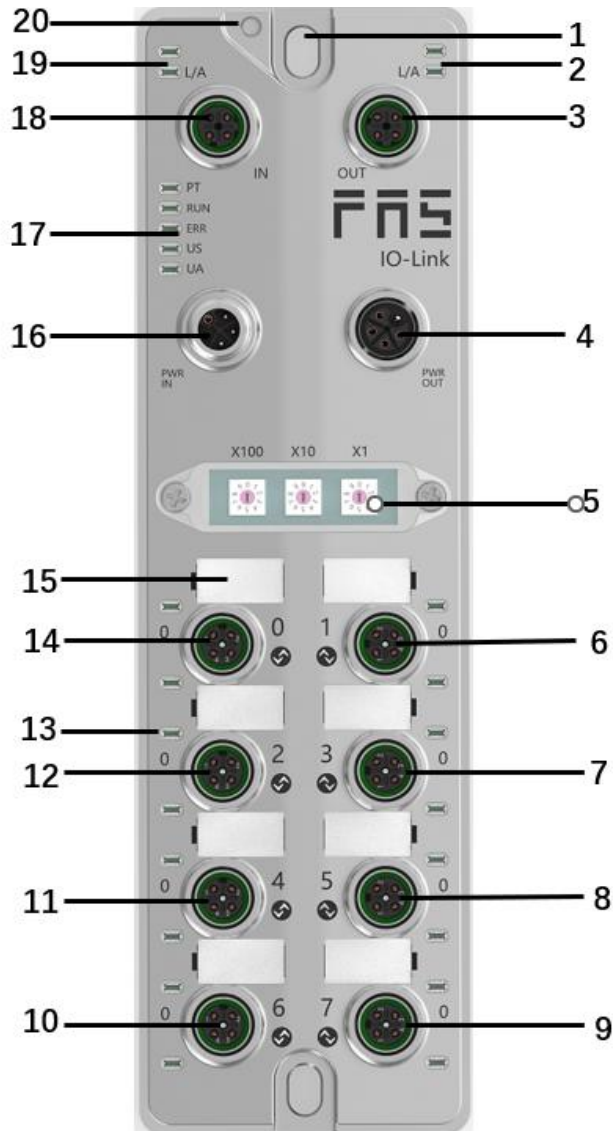

- | | |
|-----------------------------------|------------------------------------|
| 1 Mounting hole | 11 Port 4 |
| 2 Network port 2 status indicator | 12 Port 2 |
| 3 Network port 2 | 13 Port status indicator |
| 4 Power output port | 14 port 0 |
| 5 DIP switch | 15 Port identification plate |
| 6 Port 1 | 16 Power input port |
| 7 port 3 | 17 Module indicator light |
| 8 Port 5 | 18 Network port 1 |
| 9 Port 7 | 19 Network port 1 status indicator |
| 10 Port 6 | 20 Ground connection |

1.2 Mechanical connection

The modules are connected using 2 M4 bolts and 2 washers.
Isolation pads are available as accessories.

1.3 Electrical connections

1.3.1 Power interface (L-code)

Power input port definition

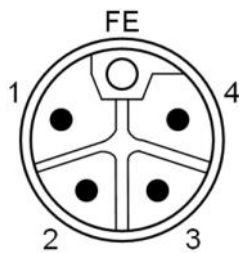

Power output port definition

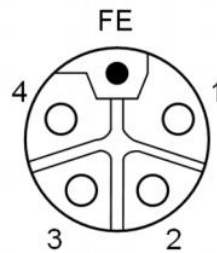

Power port

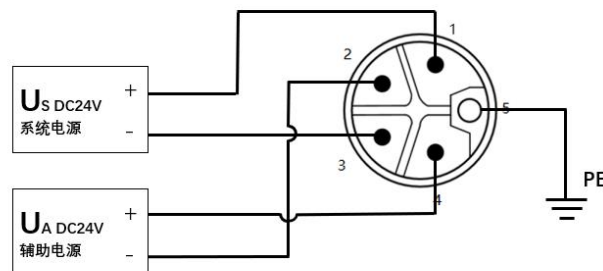

Pin	Function	Description
1	Us+	+24V(Brown)
2	Ua-*	0V(White)
3	Us-	0V(Blue)
4	Ua+*	+24V(black)
FE	Functional ground*	FE (Yellow green)

Note:

1. If possible, provide sensor/module power supply and actuator power supply separately.
The total current of all modules is <16A, even if the actuator power supply is daisy chained.
2. The FE connection from the housing to the machine must be low impedance and kept as short as possible.

1.3.2 Network Interface (D-code)

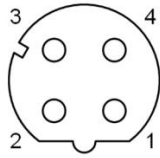

Pin	Function	
1	Tx+	Send data+
2	Rx+	Receive data+
3	Tx-	Send data-
4	Rx-	Receive data-

Note:

Unused I/O port sockets must be covered with end caps to meet IP67 protection, etc.

1.3.3 I/O-port (A-code)

Port0~Port7definition:

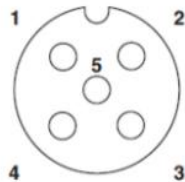

Pin	Function
1	+24V (Brown) Maximum current 1A
2	Input/output (White)
3	0V (Blue)
4	Input/Output/IOLINK (Black)
5	FE

Port4~Port7definition:

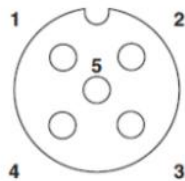

Pin	Function
1	+24V (Brown)
2	Enter (White)
3	0V (Blue)
4	Input/IOLINK (Black)
5	FE

Normal I/O

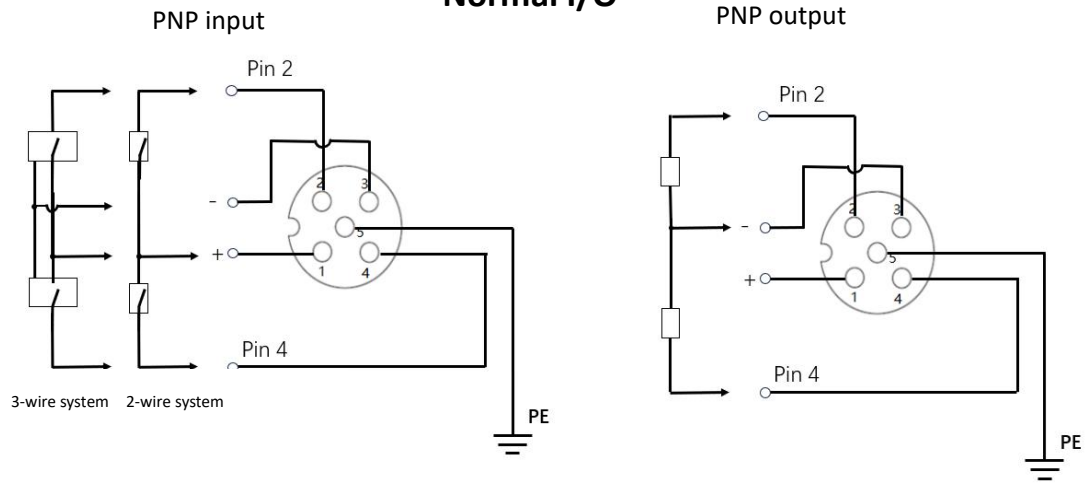

Note:

1. Regarding digital sensor input, please follow the input guidance of EN61131-2, Type 2.
2. The maximum output current of each port is 2A. The total module current is <math>< 16\text{A}</math>.
3. Unused I/O port sockets must be covered with end caps to meet IP67 protection level.

1.3.4 Master module wiring method

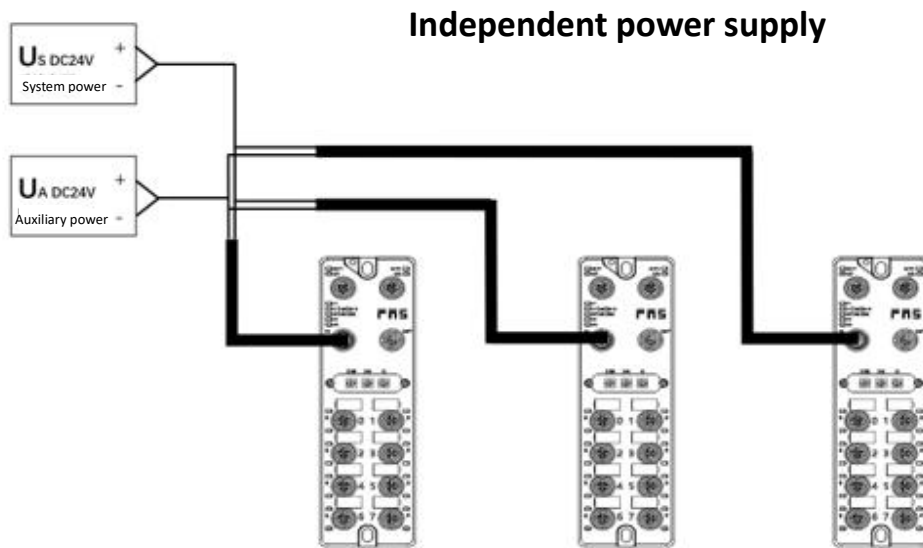

In independent power supply mode, the maximum current of each master station can reach 16A.

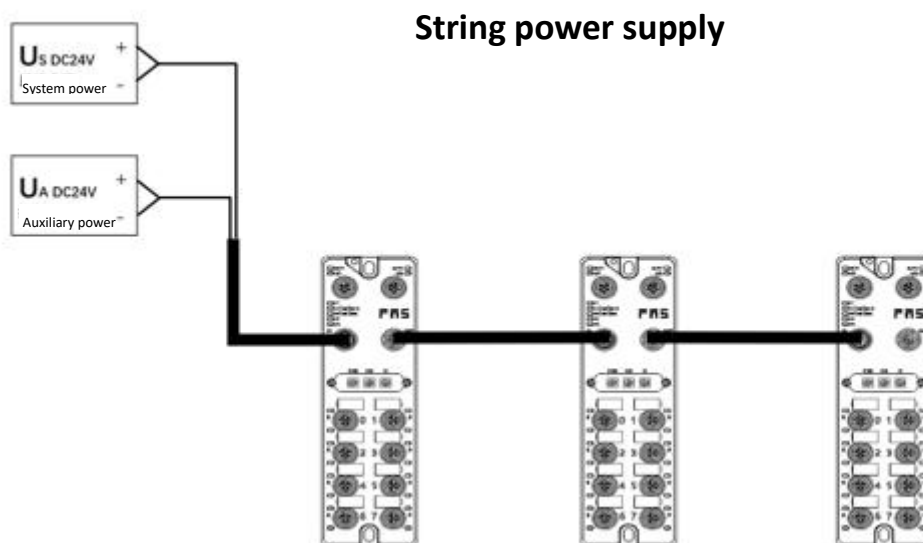

In the serial power supply wiring mode, if the rear module needs to be connected to the front module, the cumulative current must not exceed 16A.

2. Technical data

2.1 Size

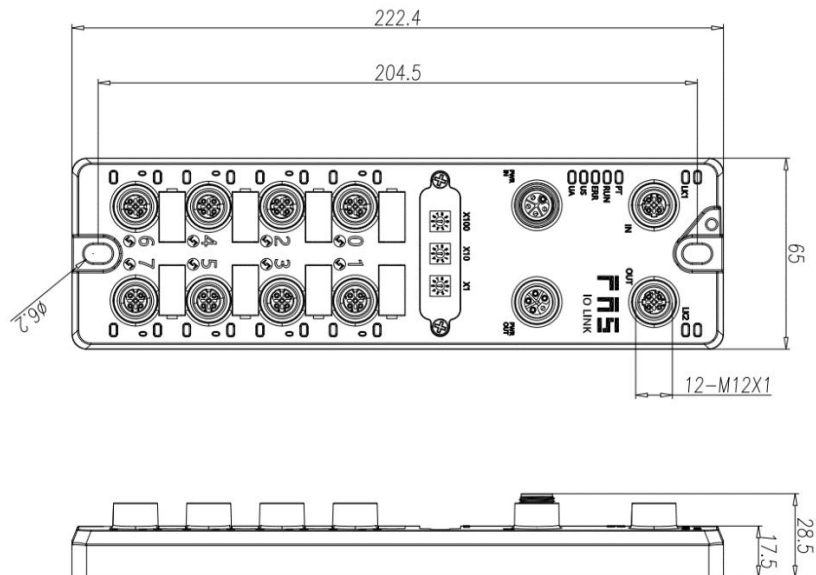

2.2 Mechanical data

Shell material	Die-cast aluminum housing, pearl nickel plated
Housing rating according to IEC 60529	IP67 (only when inserted or plugged)
Power interface	L-Code (male and female)
Input port/output port	M12, A-Code (8*Female)
Size(W*H*D)	65mm*222mm*25.8mm
Installation type	2-Through hole mounting
Ground bus accessories	M4
Weight	About 670g

2.3 Operating conditions

Operating temperature	-5°C ~ 70°C
Storage temperature	-25°C ~ 70°C

2.4 Electrical data

Voltage	18~30V DC, conform to EN61131-2
Voltage fluctuation	<1%
Input current when power supply voltage is 24V	<130mA

2.5 Network port

Port	2 x 10Base-/100Base-Tx
Port connection	M12, D-Code
IEEE 802.3 compliant cable types	Shielded twisted pair, minimum STP CAT 5/STP CAT 5e
Data transfer rate	10/100 M bit/s
Maximum cable length	100m
Flow control	Half working condition/full working condition (IEEE 802.3-PAUSE)

2.6 Function indicator



PT	Blue	EtherCat communication protocol
----	------	---------------------------------

Module status

LED	Show	Function
RUN	Green light off	Working fine
	Green light flashes 2.5HZ	Pre-operation: The device is in pre-operation state
	Flashing green 1HZ	Safe operation: The equipment is in safe operation.
	Steady green	Running: The device is running
ERR	Closure	Device EtherCAT communication is working
	Flashing red 2.5HZ	Invalid configuration
	Flashing red	Application monitoring timeout
US	1HZ	Input voltage is normal
	Red double flash	Input voltage low (< 18 V)
UA	Green	Output voltage is normal
	Flashing red	Output voltage low (< 18 V)
	Green	No output voltage present (< 11 V)

I/O port status

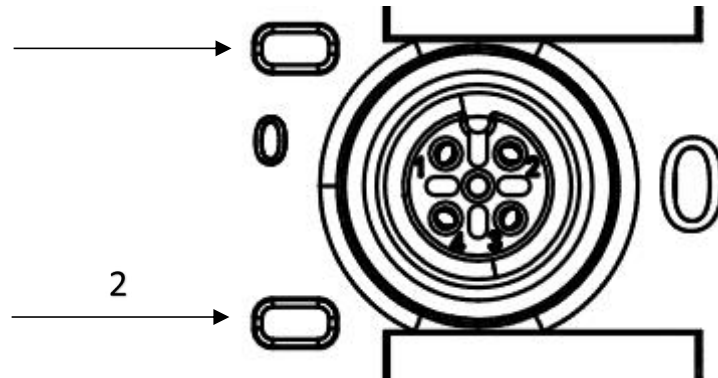

LED	State	Function
LED1	Closure	The status of Pin4 input or output is 0
LED1	Yellow	The status of Pin4 input or output is 1
LED1	Red	Port configured as output: Pin4 short circuit
LED1	Flashing red	Port configured as output: Pin1 short circuit
LED1	Green	IOLink is connected
LED1	Flashing green	IOLink not connected
LED2	Closure	The status of Pin2 input or output is 0
LED2	Yellow	The status of Pin2 input or output is 1
LED2	Red	The UA power supply is cut off or the network is disconnected or Pin2 is short-circuited.
LED2	Flashing red	Pin1 short circuit

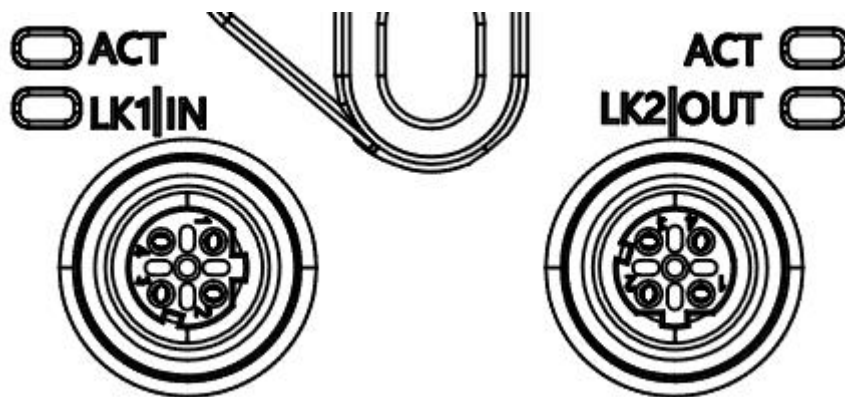

Network port status

LED	State	Function
IN(L/A)	Flashing green	Data transfer in progress
OUT (L/A)	Flashing green	Data transfer in progress

2.7 EtherCAT node address setting

1. Set by dialing (1~192 or 401~499)
 - a. Switch to the EtherCAT communication protocol. The X100 dialing code is the hundreds digit of the address, the X10 dialing code is the tens digit of the address, and the X1 dialing code is the ones digit of the address.
 - b. After dialing the code while the power is on, power on again.
2. Setting through PLC
 - a. Switch to the EtherCAT communication protocol, set the X100 dial to 0, the X10 dial to 0, and the X1 dial to 0.
 - b. Set the node address through PLC software.

3 Integrated

3.1 PLC integrated

3.1.1 Omron NX1P2 integrated in sysmac studio

Here, you will see how to integrate this module into an Omron PLC example, taking the Omron NX1P2 PLC as an example.

Install the ESI file: Configuration and Settings---EtherECT---right-click the main device---click Show ESI Library---click "Install File" in the pop-up window---select the corresponding product ESI file



Create a module: Click on the toolbox on the right---find FAS Fieldbus Modules---select product model FNI ECT-506-105-M

Double-click the corresponding product to add it to the main device

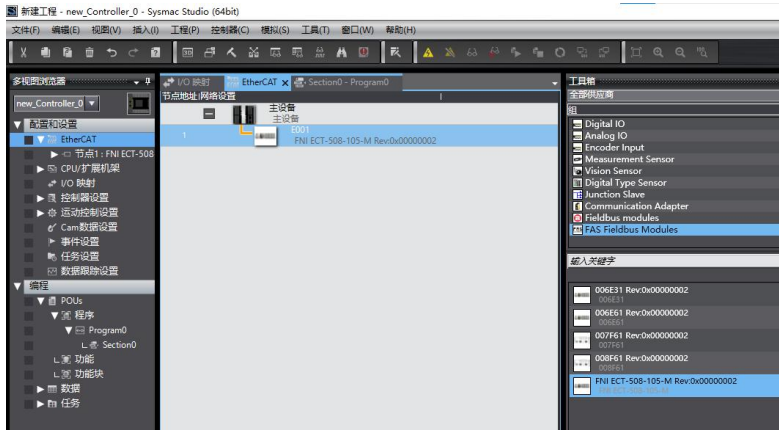

Module slot data (IOLINK mode): Right-click the module---select edit module configuration---drag the required data into the module slot---if the slave station has an output signal, you need to open the master station PIN2--- Click on I/O mapping---give Digital Output Mapping_Output Pin 2 a variable----set the port Output Pin 2 that is used for output signals in the program to 1---that means the configuration is successful!

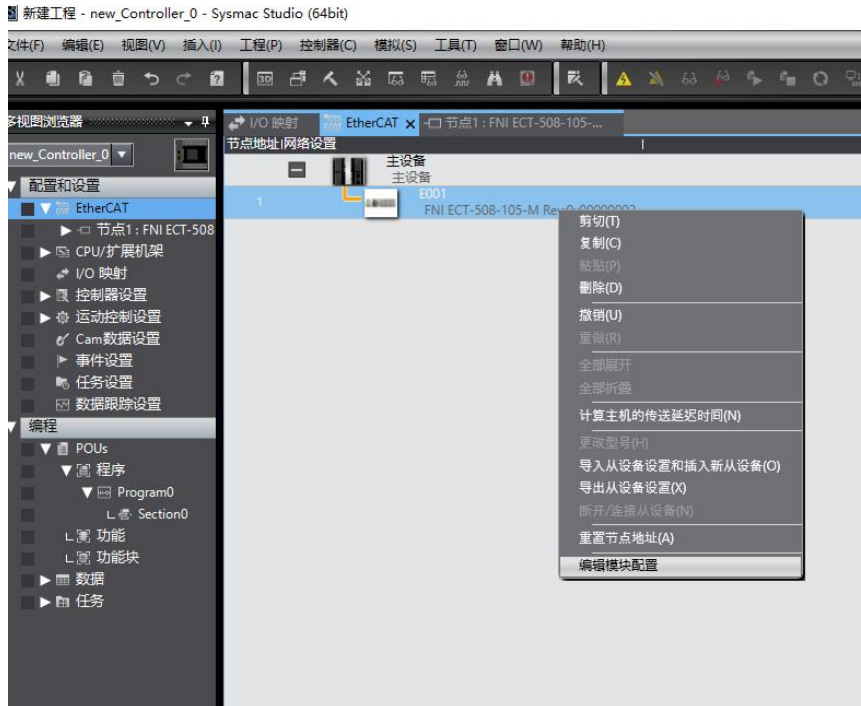

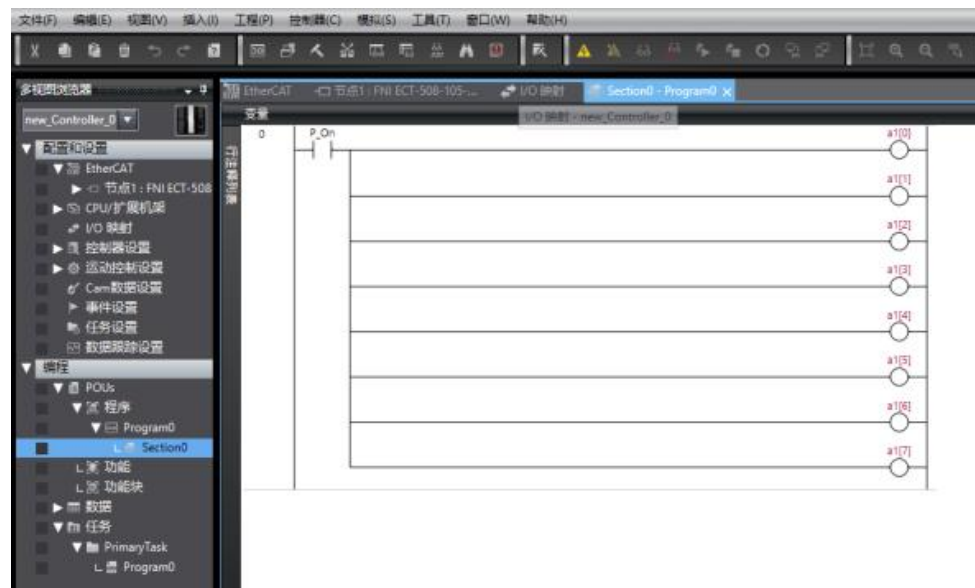
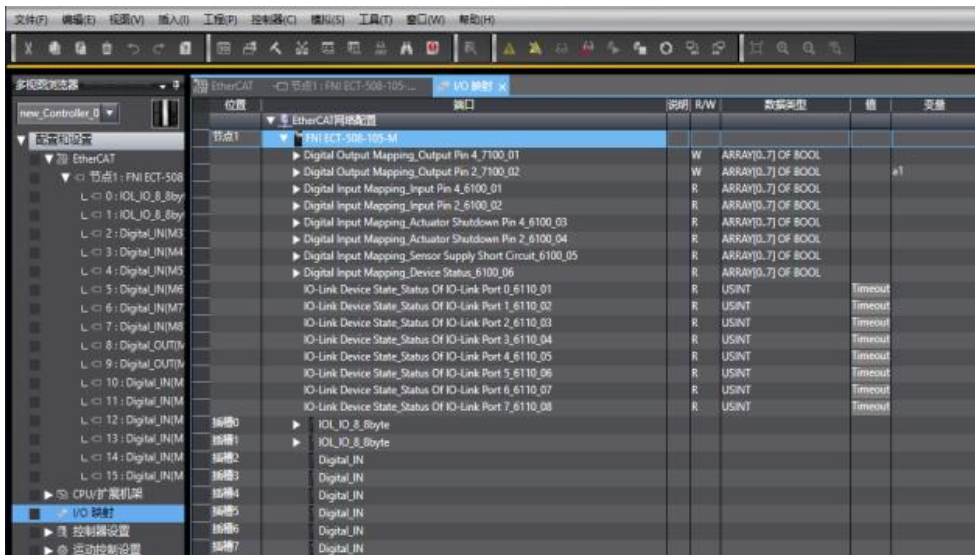
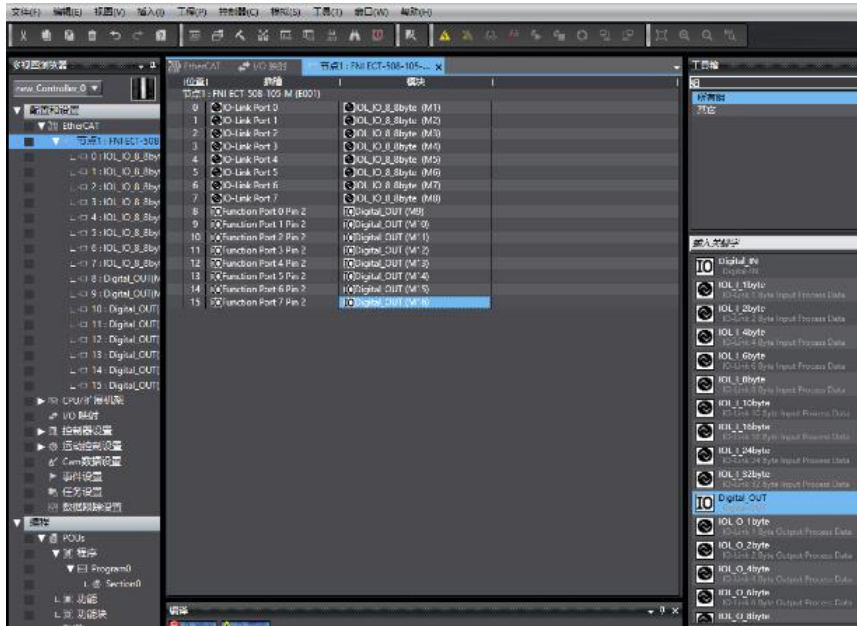

Module I/O variables:

Digital Output Mapping_Output Pin 4	Digital Output Mapping_Output Pin 4
Digital Output Mapping_Output Pin 2	Digital Output Mapping_Output Pin 2
Digital Input Mapping_Input Pin 4	Digital Input Map_Input Pin 2
Digital Input Mapping_Input Pin 2	Digital Input Map_Input Pin 2
Digital Input Mapping_Actuator Shutdown Pin 4	Input pin 4 short circuit detection
Digital Input Mapping_Actuator Shutdown Pin 2	Input pin 2 short circuit detectio
Digital Input Mapping_Sensor Supply Short circuit	Input pin 1 pin 3 short circuit detection
Digital Input Mapping_Device Status	Equipment process input status

Equipment process input status function description									
Name	Function description	Bit7	Bit6	Bit5	Bit4	Bit3	Bit2	Bit1	Bit0
Input Pin 4	Standard IO input 0=no signal 1=There is signal	Port7 Pin4	Port6 Pin4	Port5 Pin4	Port4 Pin4	Port3 Pin4	Port2 Pin4	Port1 Pin4	Port0 Pin4
Input Pin 2	Standard IO input 0=no signal 1=There is signal	Port7 Pin2	Port6 Pin2	Port5 Pin2	Port4 Pin2	Port3 Pin2	Port2 Pin2	Port1 Pin2	Port0 Pin2
Actuator Shutdown Pin 4	Short circuit detection (Pin4 short circuit) 0=no short circuit 1=There is a short circuit	Port7 Pin4	Port6 Pin4	Port5 Pin4	Port4 Pin4	Port3 Pin4	Port2 Pin4	Port1 Pin4	Port0 Pin4
Actuator Shutdown Pin 2	Short circuit detection (Pin2 short circuit) 0=no signal 1=There is signal	Port7 Pin2	Port6 Pin2	Port5 Pin2	Port4 Pin2	Port3 Pin2	Port2 Pin2	Port1 Pin2	Port0 Pin2
Sensor Supply Short circuit	Short circuit detection (Pin1 short circuit) 0=no signal 1=There is signal	Port7 Pin1	Port6 Pin1	Port5 Pin1	Port4 Pin1	Port3 Pin1	Port2 Pin1	Port1 Pin1	Port0 Pin1
Device Status	Module status	-	-	-	Us Overvoltage	Ua Overvoltage	Overheat	Us Under voltage	Ua Under voltage

3.1.2 Integrated in BECKHOFFT winCATXAE

Here you will see an example of how to integrate this module into TwinCAT XAE, using a CX5050 PLC as an example:

Add PLC path:

Right-click the TwinCAT icon in the lower right corner to open Edit Routes

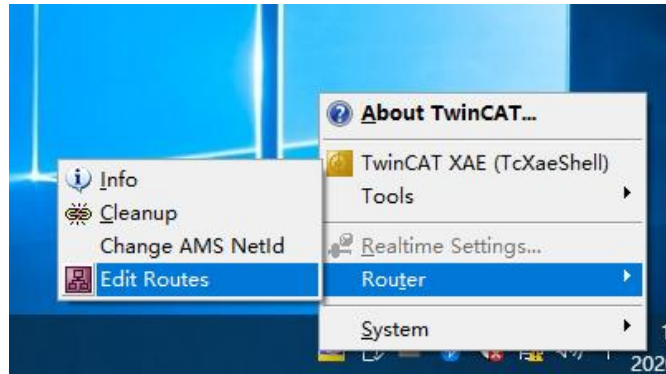

Click Add...;Add route (Add Route Dialog)

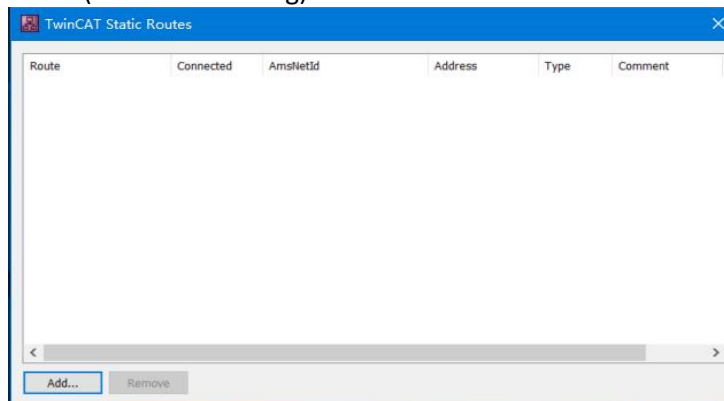

Broadcast Search- choose PLC(CX-3D0A4)-Add Route

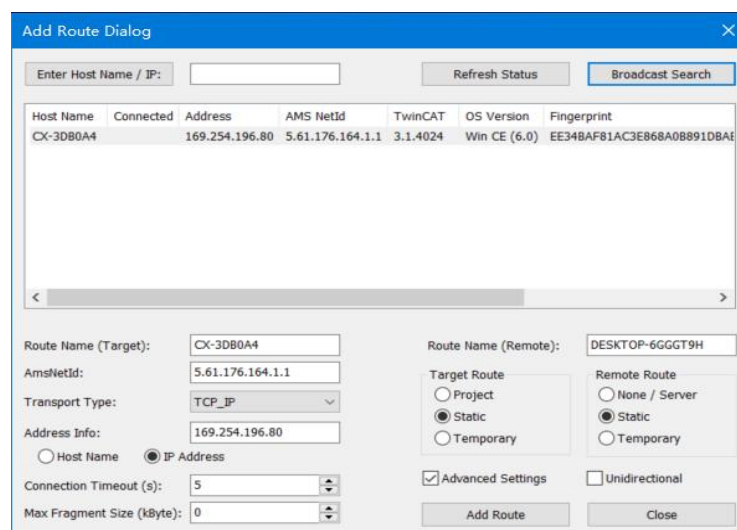

Enter the default password "1" - click OK to complete adding the PLC path

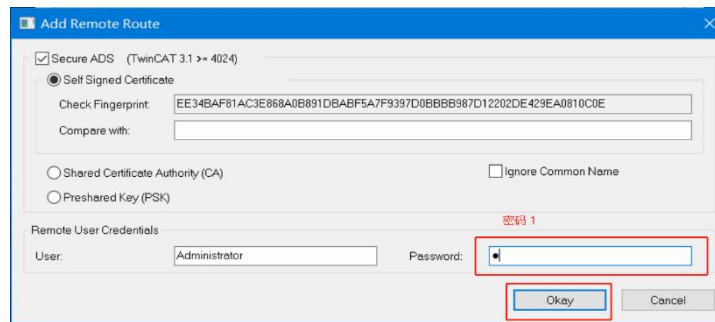

Add device profile: FAS FNI-ECT-506-105 (provided by FAS)

Copy the file to the following path to complete adding the configuration file:

C:\TwinCAT\3.1\Config\IO\EtherCAT

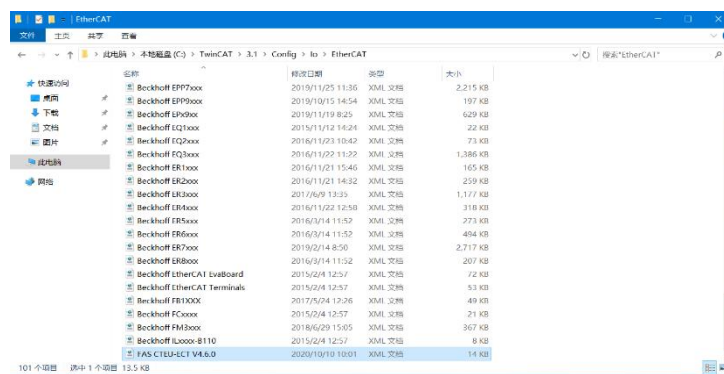

New Construction:

Open the TwinCAT XAE software---File-New-Project---Select TwinCAT XAE Project-Enter the name-OK

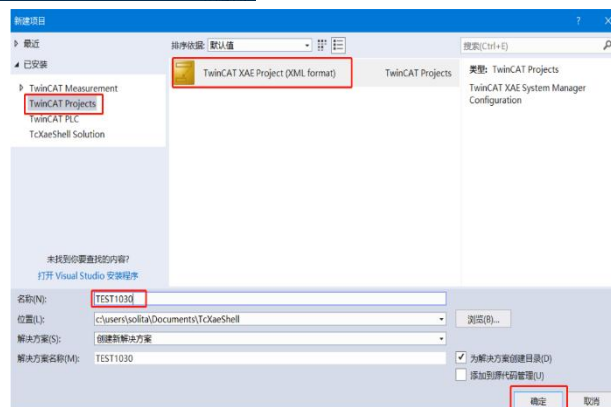

Select target system:

SYSTEM-Choose Target System-Select PLC(CX-3DB0A4)-OK

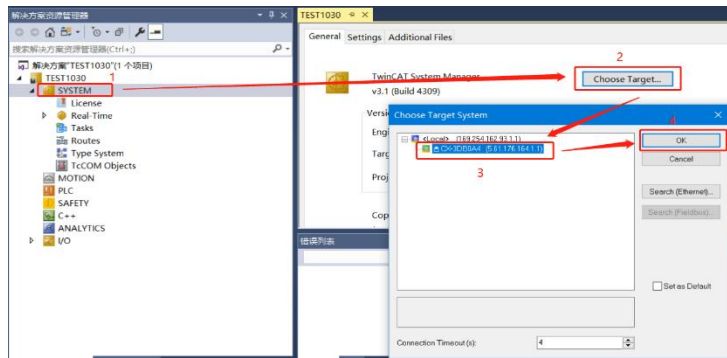

Add module:

Pull down the IO option-DEVICES-SCAN; search for the master station, select Device 2 (EtherCAT)-OK

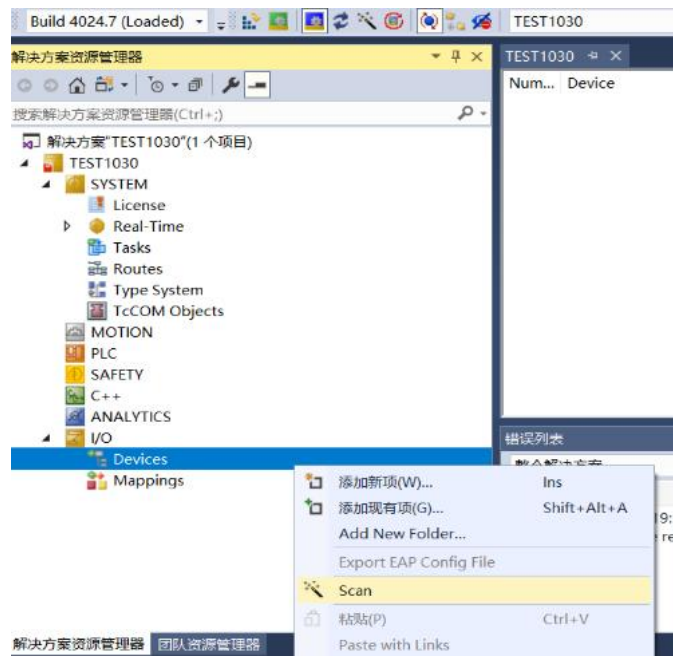

Module slot data (IOLINK mode):

Find the module FNI-ECT-508-105-M under the resource manager, select Slots, and select the required slot data for configuration.

Slots 0~7 are PIN4 functions and slots 8~15 are PIN2 functions.

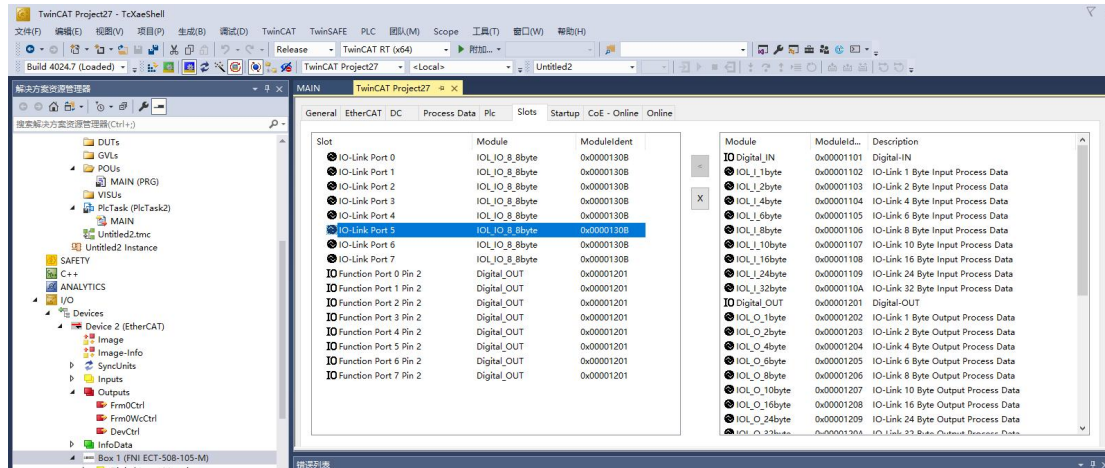

When the variable Output PIN2 is set to 1, PIN2 is enabled. When it is set to 0, PIN2 is turned off.

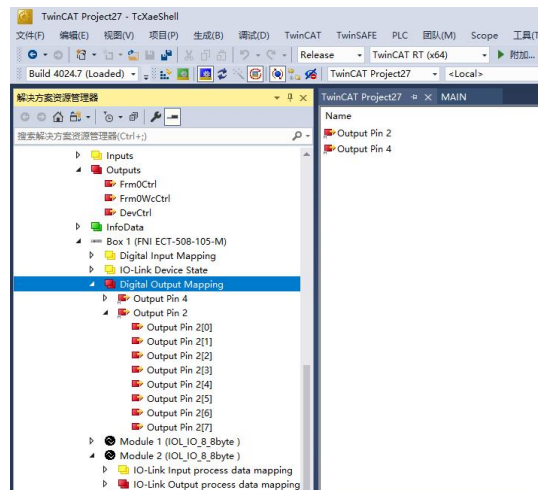

Module slave data settings (COE settings):

Find the module FNI-ECT-508-105-M under the resource manager and click COE-On-line

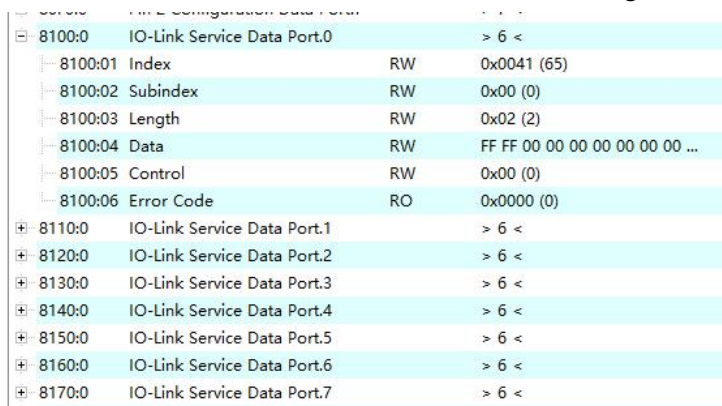

Address	IO-Link Service Data Port	Access	Value
8100:0	IO-Link Service Data Port.0		> 6 <
8100:01	Index	RW	0x0041 (65)
8100:02	Subindex	RW	0x00 (0)
8100:03	Length	RW	0x02 (2)
8100:04	Data	RW	FF FF 00 00 00 00 00 00 00 ...
8100:05	Control	RW	0x00 (0)
8100:06	Error Code	RO	0x0000 (0)
8110:0	IO-Link Service Data Port.1		> 6 <
8120:0	IO-Link Service Data Port.2		> 6 <
8130:0	IO-Link Service Data Port.3		> 6 <
8140:0	IO-Link Service Data Port.4		> 6 <
8150:0	IO-Link Service Data Port.5		> 6 <
8160:0	IO-Link Service Data Port.6		> 6 <
8170:0	IO-Link Service Data Port.7		> 6 <

8100:0: Master Pro 0 port data setting

8110:0: Master Pro 1 port data setting

8120:0: Master Pro 2 port data setting

8130:0: Master Pro 3 port data settings

8140:0: Master Pro 4 port data settings

8150:0: Master Pro 5 port data settings

8160: 0: Master Pro 6 port data settings

8170:0: Master Pro 7 port data settings

Set parameters and data according to the slave module manual.

Index: Index
 Subindex: Subindex
 Length: Data length BYTE type **(when reading or writing, fill in the data length first)**
 Data: Data mapping
 Control: 1=read 2=write
 Error code: Error code

IOLINK slave station configuration (this function is online configuration, the slave station and the master station should maintain normal communication)

(1) When you need to configure the IOLINK slave station, you should write to set Pin4 as the IOLINK function, and write 2 data to Control to complete the configuration and the slave station will take effect;



Note that the input values of Index and Subindex are in decimal, and the input and output values of Data are in hexadecimal;

(2) Common index functions of FAS slave stations:

Example: a. Input and output configuration: Index =65, Subindex=0; the following figure is an example of slave station configuration:

Notice:

- “功能说明” Ttranslate: “Function Description”
- “从站” Ttranslate: “Slaves”
- “从站扩展” Ttranslate: “Slave extension”
- “IP67 防护等级对应 PIN 针脚” Ttranslate: “IP67 protection level corresponding PIN pin”
- “端口号” Ttranslate: “The port number”
- “对应针脚” Ttranslate: “Corresponding pins”
- “IP20 防护等级对应 PIN 针脚” Ttranslate: “IP20 protection level corresponding PIN pin”
- “2 进制值(0 表示输入,1 表示输出)”Ttranslate:“Binary value (0 represents input, 1 represents output)”
- “16 进制值（填入到数据）” Ttranslate: “Hexadecimal value (fill in the data)”

功能说明		从站																从站扩展																
IP67防护等级产品对应PIN脚		端口号	7	6	5	4	3	2	1	0	7	6	5	4	3	2	1	0	7	6	5	4	3	2	1	0	7	6	5	4	3	2	1	0
		对应PIN脚	PIN4				PIN2				PIN4				PIN2																			
IP20防护等级产品对应PIN脚		端口号	8	7	6	5	4	3	2	1	16	15	14	13	12	11	10	9	/															
		2进制值(0表示输入,1表示输出)	1	1	1	1	1	1	1	1	1	1	1	1	1	1	1	1	1	1	1	1	1	1	1	1	1	1	1	1	1	1	1	
16进制值(填入到Data)		F				F				F				F				F				F												

For example: The slave module DI/DO requirement is full output (FFFF)

Index=65 (Known from the site manual)

Subindex=0

Length=2

Data=FFFF

Control=2 Enter

The writing is successful and the module configuration changes to full output.

3.1.2 Integrated in Inovance AM600-CPU1608TP/TN

Here you will see an example of how to integrate this module into Inproshop, taking the AM600-CPU1608TP/TN PLC as an example:

Add new project:

Select the corresponding PLC model for a new project

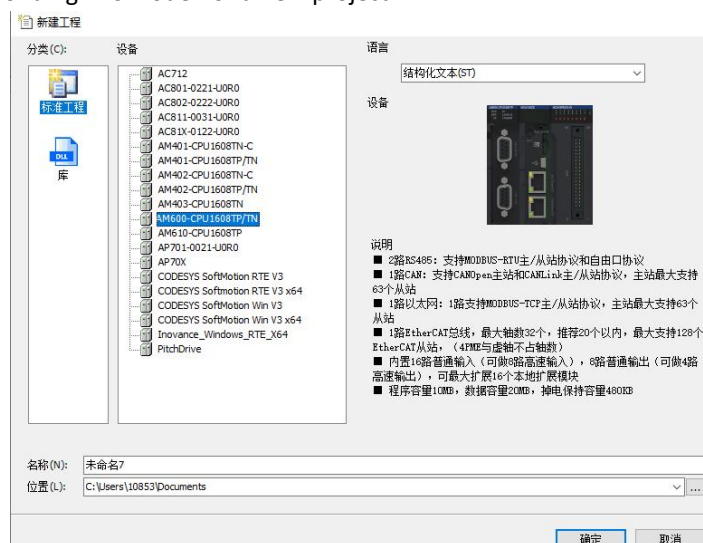

Add module:

Double-click the network configuration----click to import the ECT file----select the master station description file FNI-ECT-506-105-M

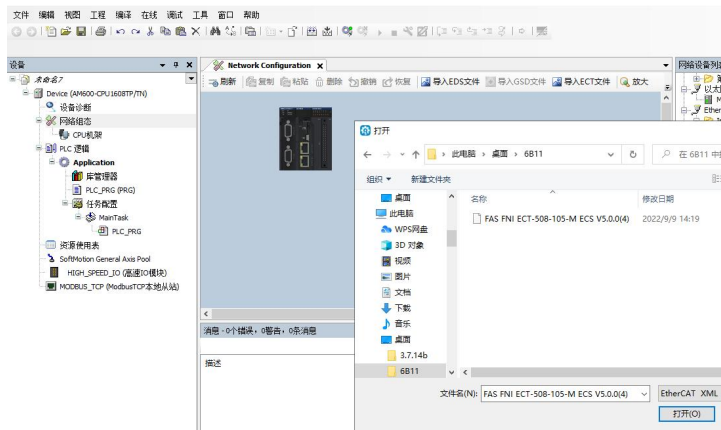

Click PLC---Check the EtherCAT master station---Select the device on the left-----right-click
ETHERCAT----Scan device

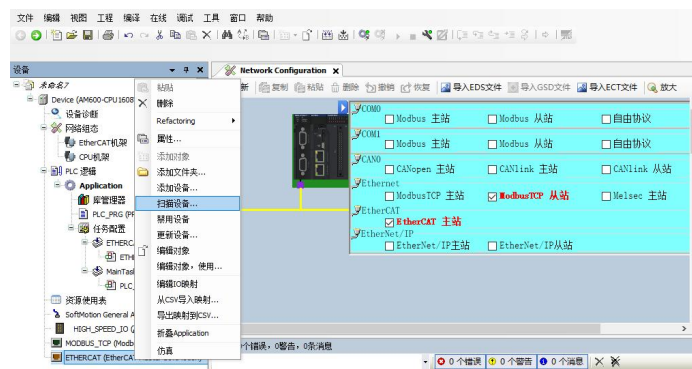

Module slot data:

Double-click the device box module FNI-ECT-508-105-M on the left -----Slot configuration-----Select the required slot data for configuration
Slots 0~7 are PIN4 functions and slots 8~15 are PIN2 functions.

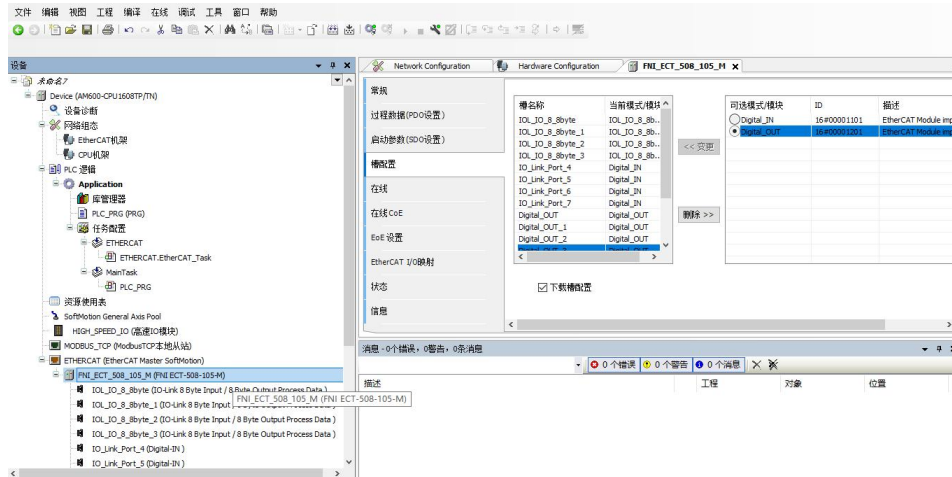

Module slot PIN2 data setting:

If the slave module has an output signal connected, the PIN2 of the master module must be turned on and assigned in the program-----configuration completed!

When the variable Output PIN2 address is set to 1, PIN2 is enabled. When it is set to 0, PIN2 is turned off.

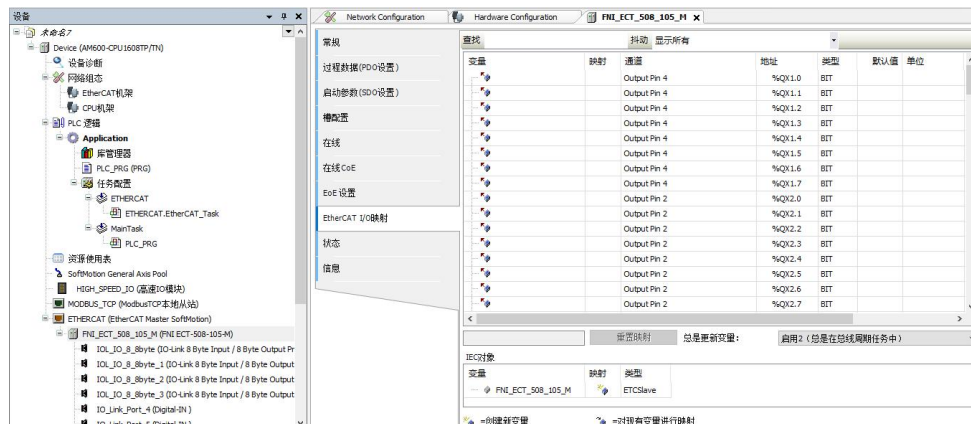

4.Appendix

4.1 Materials included

- FNI ECT contains the following parts
- I/O-Block
- 4 blind plugs M12
- Ground bus
- Thread M4x6
- 20 tags

4.2 Order code

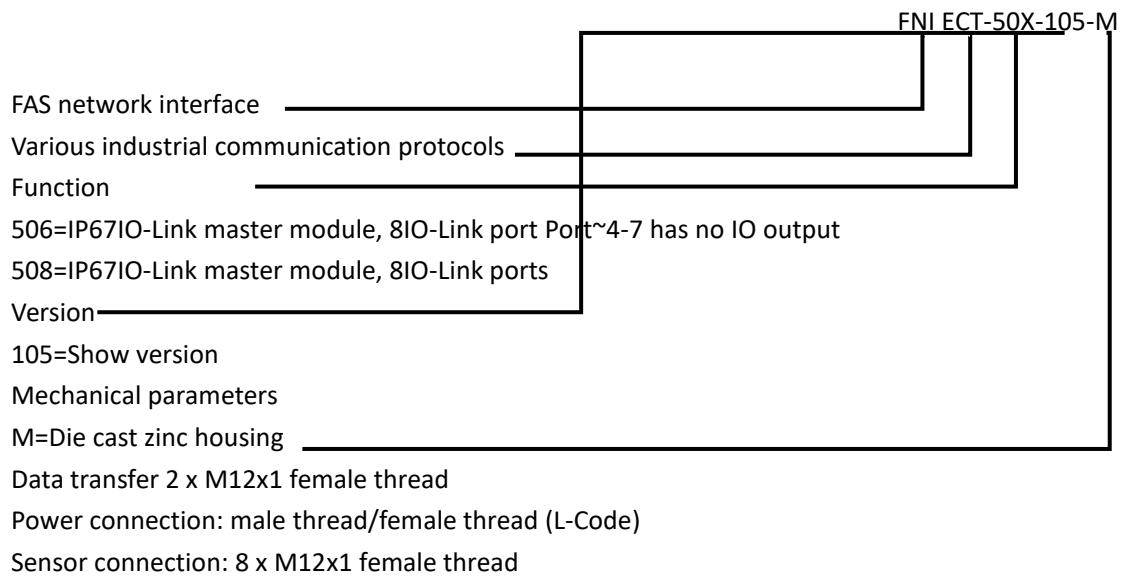

4.3 Ordering information

Product ordering code	Order code
FNI ECT-506-105-M	006B31

High quality products · Sincere service



[Technical support]



[Official website]



Telephone : 0591-22991876

Technical support : +86 13306936805

Official website: www.faselec.com

Business support : +86 19905006938

Address: Room 009, A1, Building 1, National University Science and Technology Park Science and Technology Innovation Center, No. 6 Qiuyang East Road, Shangjie Town, Minhou County, Fujian Province.