



# PRODUCT

USE INSTRUCTIONS

---



[ Technical support ]

**Ordering code: 007B31**

**Part number: FNI MPL-506-105-M**

# FNI MPL-506-105-M

8xIO-Link,16 DI/8 DO PNP

## IO-Link master module user manual



## Contents

<b>Security</b> .....	4
■ Expected use .....	4
■ Installation and start-up .....	4
■ Corrosion resistance .....	4
■ Dangerous voltage .....	4
■ General security .....	5
<b>1 Getting started guide</b> .....	6
1.1 Module overview .....	6
1.2 Mechanical connection .....	7
1.3 Electrical connections .....	7
1.3.1 Power interface (L-code) .....	7
1.3.2 Network interface (D-code) .....	8
1.3.3 I/O-port (A-code) .....	8
1.3.4 Master module wiring method .....	9
<b>2 Technical data</b> .....	9
2.1. Size .....	10
2.2 Mechanical data .....	10
2.3 Operating conditions .....	10
2.4 Electrical data .....	10
2.5 Network port .....	11
2.6 Function indicator .....	11
<b>3 Integrated</b> .....	13
3.1 Module configuration .....	13
3.1.1 Restore factory settings and switch communication protocols .....	14
3.1.2 Network segment modification (only applicable to EIP and CCIEBS communication protocols) .....	14
3.1.3 CCIEBS setting the number of occupied stations .....	15
3.2 Data mapping .....	16
3.3 PLC integration tutorial .....	24
3.3.1 Siemens S7-1200 Botu Integration (PN) .....	24
3.3.2 Omron NX1P2 Sysmac Studio Integrated (EIP) .....	26
3.3.4 Mitsubishi FX5U Work2 integrated (CCIEBS) .....	28
<b>4 Appendix</b> .....	30
4.1. Materials included .....	30
4.2. Order code .....	30
4.3. Ordering information .....	30

## ■ Expected use

This manual describes as decentralized input and output modules for connecting to an industrial network.

---

## ■ Installation and start-up

Precautions!

Installation and start-up may only be performed by trained personnel. A qualified individual is one who is familiar with the installation and operation of the product and has the necessary qualifications to perform such operations. Any damage caused by unauthorized operation or illegal and improper use is not covered by the manufacturer's warranty. The equipment operator is responsible for ensuring that appropriate safety and accident prevention regulations are observed.

---

## ■ Corrosion resistance

Precautions!

FNI modules generally have good chemical and oil resistance. When used in corrosive media (e.g. high concentrations of chemicals, oils, lubricants, coolants and other material media (i.e. very low water content), these media must be checked before the corresponding application material compatibility. If a module fails or is damaged due to this corrosive medium, a defect claim cannot be made.

---

## ■ Dangerous voltage

Precautions!

Disconnect all power before using the device!

---

## ■ General security

Debugging and inspection	Fault	Owner/operator obligations	Expected use
<p>Before debugging, read the user manual carefully.</p>	<p>If the defect or equipment failure cannot be corrected, the operation of the equipment must be stopped to avoid damage that may be caused by unauthorized use.</p>	<p>This equipment is an EMC Class A compliant product. This device produces RF noise.</p>	<p>The warranty and limited liability statement provided by the manufacturer does not cover damage caused by:</p> <ul style="list-style-type: none"> <li>·Unauthorized tampering</li> <li>·Improper use operation</li> </ul> <p>·The instructions provided in the user manual explain the use, installation and handling of discrepancies</p>
<p>This system cannot be used in an environment where the safety of personnel depends on the functionality of the equipment.</p>	<p>Only after the housing is fully installed can the intended use be assured.</p>	<p>The owner/operator must take appropriate precautions to use this equipment.</p> <p>This device can only use the power supply that matches this device, and can only connect cables approved for application.</p>	

# 1. Getting Started Guide

## 1.1 Module overview

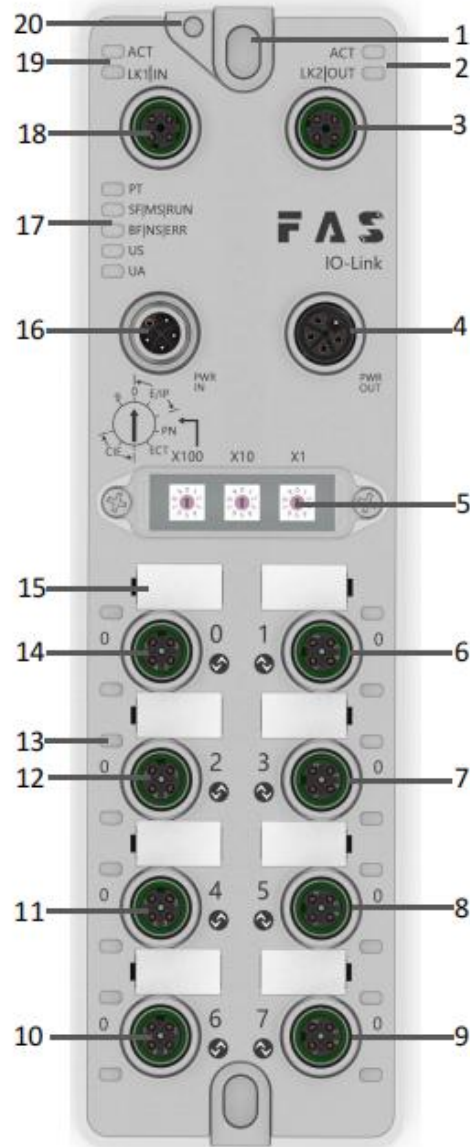

- |                                   |                          |                                    |
|-----------------------------------|--------------------------|------------------------------------|
| 1 Mounting hole                   | 8 Port 5                 | 15 Port identification plate       |
| 2 Network port 2 status indicator | 9 Port 7                 | 16 Power input port                |
| 3 Network port 2                  | 10 Port 6                | 17 Module indicator light          |
| 4 Power output port               | 11 Port 4                | 18 Network port 1                  |
| 5 DIP switch                      | 12 Port 2                | 19 Network port 1 status indicator |
| 6 Port 1                          | 13 Port status indicator | 20 Ground connection               |
| 7 port 3                          | 14 port 0                |                                    |

## 1.2 Mechanical connection

The modules are connected using 2 M6 bolts and 2 washers.  
Isolation pads are available as accessories.

## 1.3 Electrical connection

### 1.3.1 Power interface (L-code)

Definition of power input port

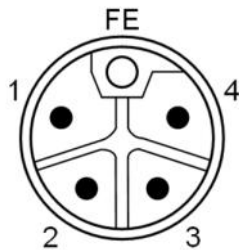

Definition of power output port

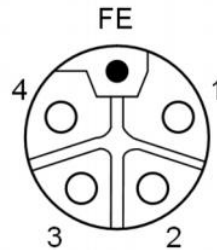

I Power port

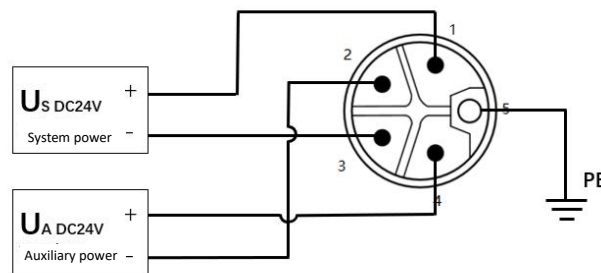

Pin	Function	Description
1	Us+	+24V(Brown)
2	Ua-*	0V(White)
3	Us-	0V(Blue)
4	Ua+*	+24V(Black)
FE	Functional ground*	FE (Yellow green)

Note:

1. If possible, provide sensor/module power supply and actuator power supply separately.  
The total current of all modules is <16A, even if the actuator power supply is daisy chained.
2. The FE connection from the housing to the machine must be low impedance and kept as short as possible.

### 1.3.2 Network interface (D-code)

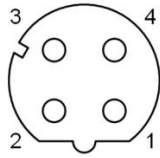

Pin	Function	
1	Tx+	Send data+
2	Rx+	Receive data+
3	Tx-	Send data-
4	Rx-	Receive data-

Note:

Unused I/O port sockets must be covered with end caps to meet IP67 protection rating.

### 1.3.3 I/O-port (A-code)

Port0~Port3 definition:

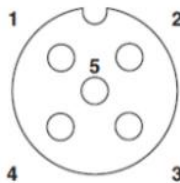

Pin	Function	
1	+24V (Brown)	maximum current 1A
2	Input /Output	(White)
3	0V	(Blue)
4	Input/Output/IOLINK	(Black)
5	FE	

Port4~Port7definition:

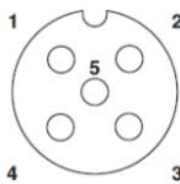

Pin	Function	
1	+24V (Brown)	maximum current 1A
2	Enter	(White)
3	0V	(Blue)
4	Input/IOLINK	(Black)
5	FE	

### Normal I/O

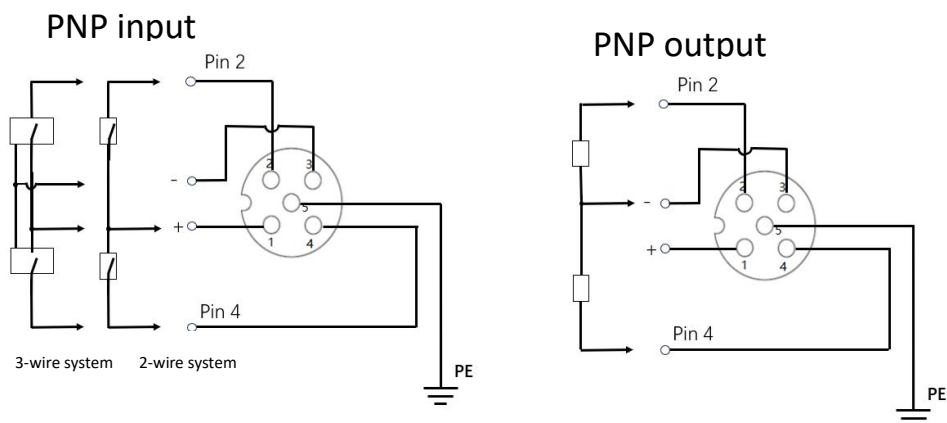

Note:

1. Regarding digital sensor input, please follow the input guidance of EN61131-2, Type 2.
2. The maximum output current of each port is 2A. The total module current is 16A.
3. Unused I/O port sockets must be covered with end caps to meet IP67 protection level.



### 1.3.4 Master module wiring method

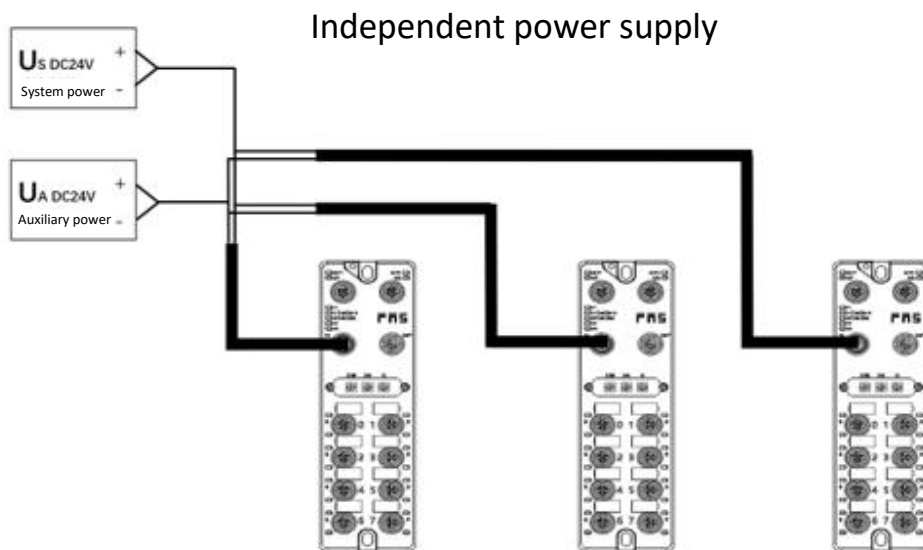

In independent power supply mode, the maximum current of each master station can reach 16A.

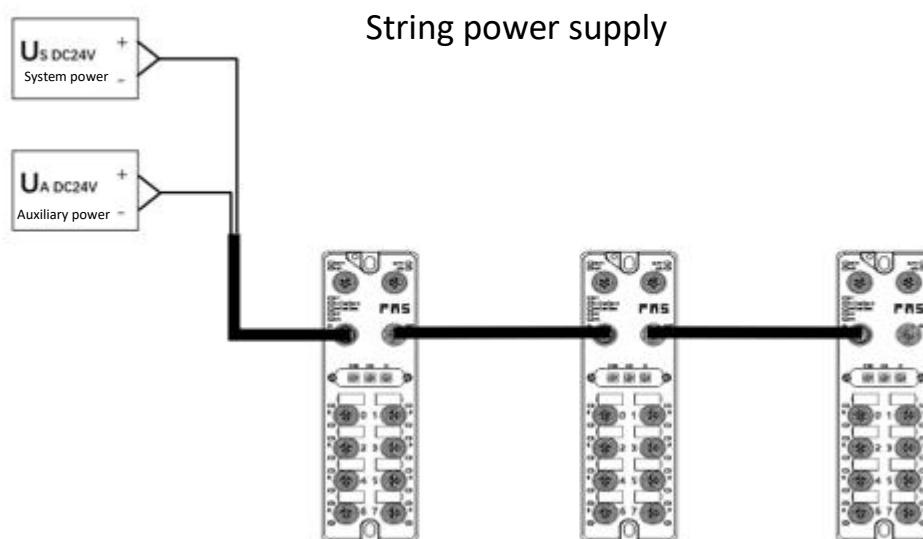

In the serial power supply wiring mode, if the rear module needs to be connected to the front module, the cumulative current must not exceed 16A.

## 2. Technical data

### 2.1 Size

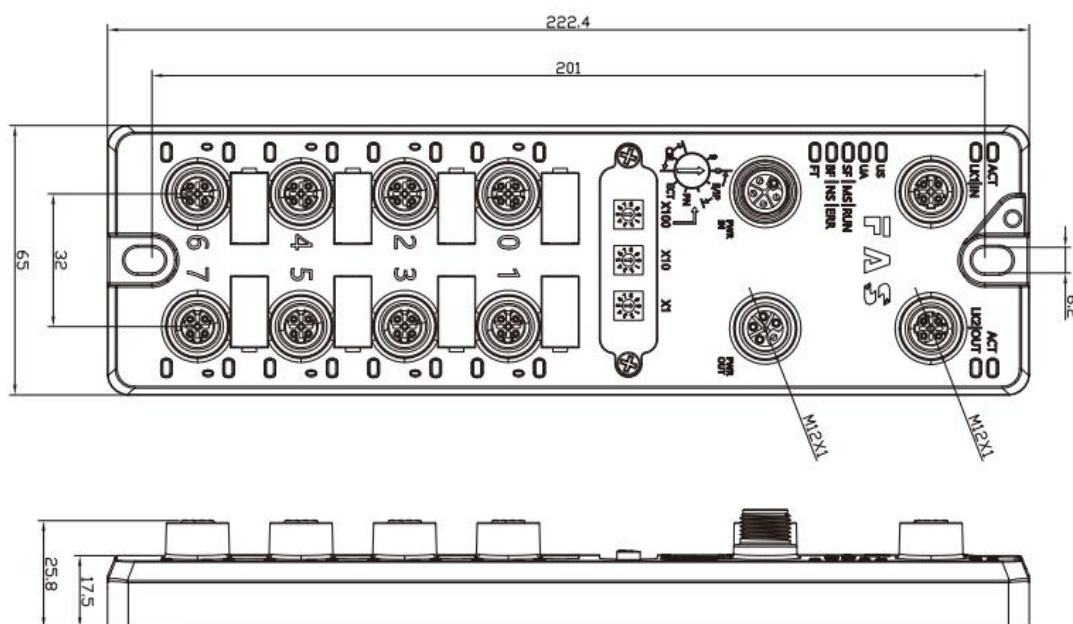

### 2.2 Mechanical data

Shell material	Die-cast aluminum housing, pearl nickel plated
Housing rating according to IEC 60529	IP67 Only when inserted or plugged)
Power interface	L-Code (male and female)
Input port/output port	M12, A-Code (8*Female)
Size(W*H*D)	65mm*222mm*25.8mm
Installation type	2-Through hole mounting
Ground bus accessories	M4
Weight	About 670g

### 2.3 Operating conditions

Operating temperature	-5°C ~ 70°C
Storage temperature	-25°C ~ 70°C

### 2.4. Electrical data

Voltage	18~30V DC, conform to EN61131-2
Voltage fluctuation	< 1%
Input current when power supply voltage is 24V	<130mA

## 2.5 Network port

Port	2 x 10Base-/100Base-Tx
Port connection	M12, D-Code
IEEE 802.3 compliant cable types	Shielded twisted pair, minimum STP CAT 5/STP CAT 5e
Data transfer rate	10/100Mbit/s
Maximum cable length	100m
Flow control	Half working condition/full working condition (IEEE 802.3-PAUSE)

## 2.6 Function indicator



PT	Green	EtherNet/IP communication protocol
	Yellow	ProfiNet communication protocol
	Blue	EtherCat communication protocol (reserved)
	White	CC-Link IE Field basic communication protocol

### EtherNet/IP communication protocol module status

LED	Show	Function
MS	Green light is always on	Working status: The equipment is running normally
	Green light flashes 1HZ	Standby: The device is not configured
	Flashing green, red and green alternately	Self-test: The device is undergoing a power-on self-test.
	Flashing red 1HZ	Recoverable faults:
	Red light always on	Unrecoverable failure
	Closure	US no input voltage
NS	Green light is always on	Connected
	Green light flashes 1HZ	Not connected
	Flashing green and red alternately	Self-test: The device is undergoing a power-on test.
	Red light flashes 1HZ	Connection timed out
	Red light always on	Duplicate IP
	Closure	USNo input voltage or no IP address
US	Green	Input voltage is normal
	Flashing red	Input voltage low (< 18 V)

UA	Green	Output voltage is normal
	Flashing red	Output voltage low (< 18 V)
	Red always on	No output voltage present (< 11 V)

Profinet communication protocol module status

LED	Show	Function
SF	Closure	Working fine
	Flashing red 3s 1HZ	Bus start
	Red always on	System error
BF	Closure	Working fine
	Flashing red 2HZ	No data exchange
	Red always on	No configuration; or low speed physical link; or no physical link
US	Green	Input voltage is normal
	Flashing red	Input voltage low (< 18 V)
UA	Green	Output voltage is normal
	Flashing red	Output voltage low (< 18 V)
	Red always on	No output voltage present (< 11 V)

CC-Link IE Field Basic communication protocol module status

LED	Show	Function
RUN	Green light off	Module not connected
	Green light flashes 2.5HZ	Module has no communication
	Green light flashes 10HZ	Module not configured
	Steady green	Running: The device is running
	Closure	Module disconnected
ERR	Closure	Module disconnected
	Red light always on	Communication error
	Red light flashing	Watchdog timeout
US	Green	Input voltage is normal
	Flashing red	Input voltage low (< 18 V)
UA	Green	Output voltage is normal
	Flashing red	Output voltage low (< 18 V)
	Red always on	No output voltage present (< 11 V)

I/O port status

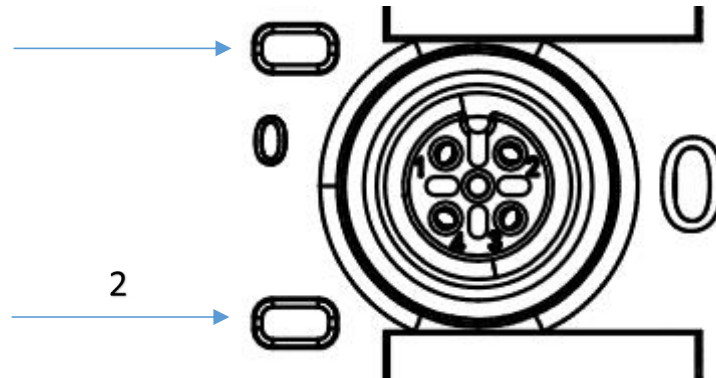

LED	State	Function
LED1	Closure	The status of Pin4 input or output is 0
LED1	Yellow	The status of Pin4 input or output is 1
LED1	Red	Port configured as output: Pin4 short circuit
LED1	Flashing red	Pin1 short circuit
LED1	Green	IOLink is connected
LED1	Flashing green	IOLink not connected
LED2	Closure	The status of Pin2 input or output is 0
LED2	Yellow	The status of Pin2 input or output is 1
LED2	Red	The UA power supply is cut off or the network is disconnected or Pin2 is short-circuited.
LED2	Flashing red	Pin1 short circuit

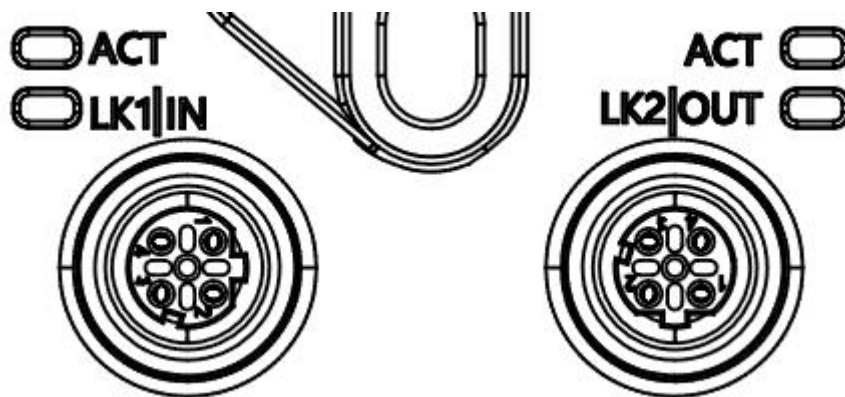

Network port status

LED	State	Function
ACT	Closure	Bus rate: 10Mbit/s
	Yellow	Bus rate: 100Mbit/s
LK1 IN (ECT IN)	Flashing green	Data transfer in progress
LK2 IN (ECT OUT)	Flashing green	Data transfer in progress

# 3.Integrated

## 3.1 Module configuration

### 3.1.1 Restoring factory settings and switching communication protocols

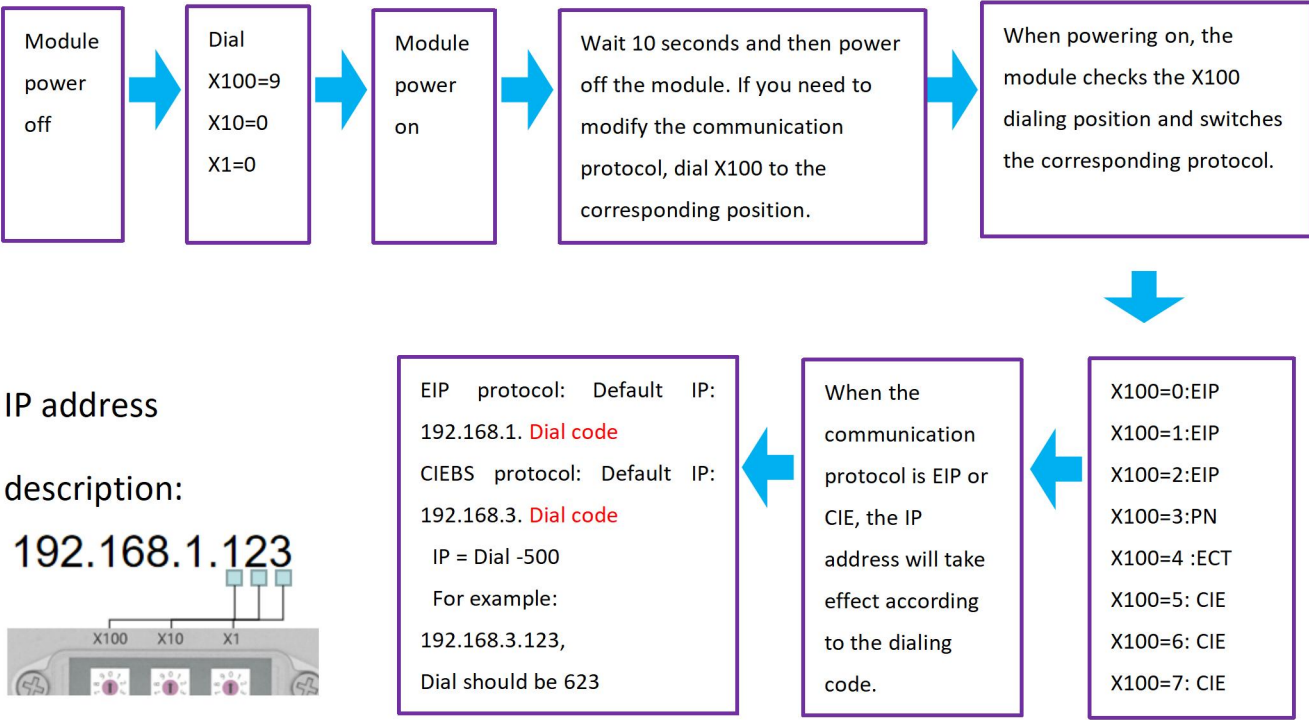

### 3.1.2 Network segment modification (only applicable to EIP and CCIEBS communication protocols)

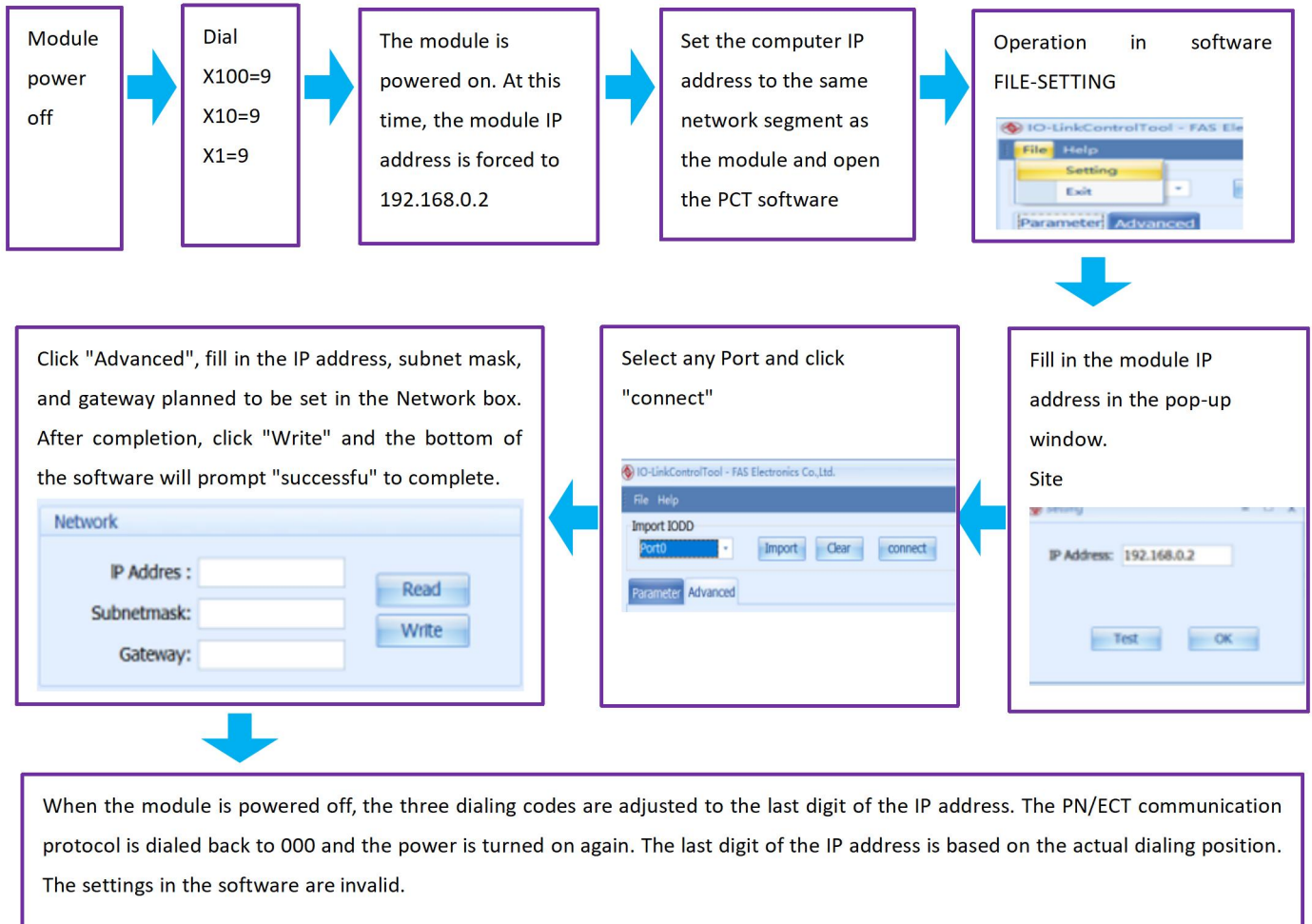

### 3.1.3 Setting the number of CCIEBS occupied stations

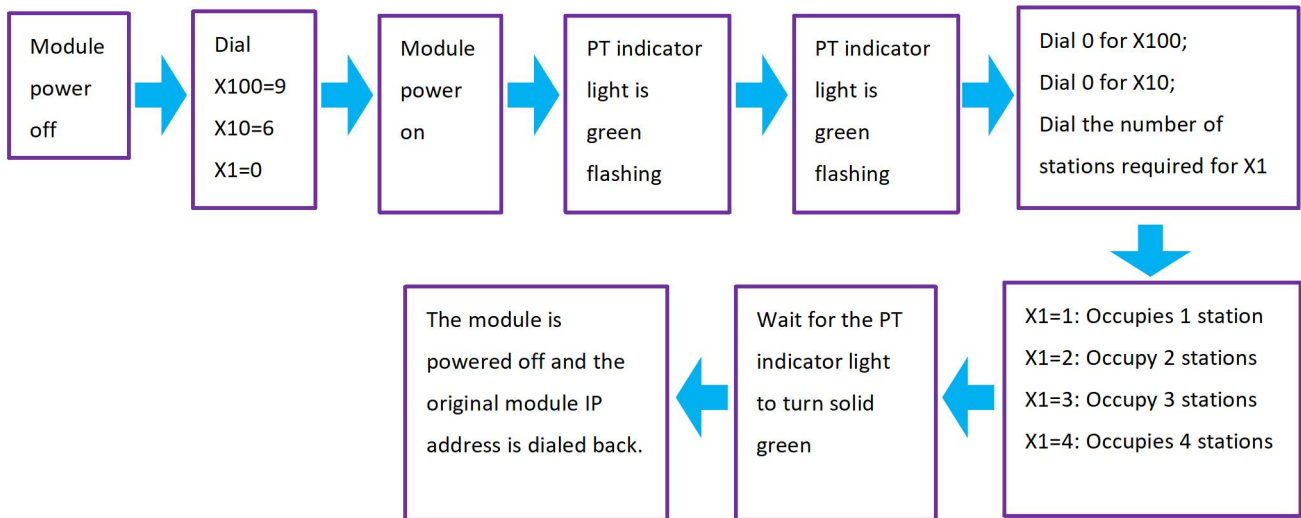

### 3.2 Data mapping

EIP communication protocol process output data									
Byte	Function description								
	Function description	Bit7	Bit6	Bit5	Bit4	Bit3	Bit2	Bit1	Bit0
0	Standard IO output	-	-	-	-	Port3 Pin4	Port2 Pin4	Port1 Pin4	Port0 Pin4
1	0=off 1=on	-	-	-	-	Port3 Pin2	Port2 Pin2	Port1 Pin2	Port0 Pin2
2 ~ 5	reserve								
6-37	Port 0 process output data								
38-69	Port 1 process output data								
70-101	Port 2 process output data								
102-133	Port 3 process output data								
134-165	Port 4 process output data								
166-197	Port 5 process output data								
198-229	Port 6 process output data								
230-261	Port 7 process output data								



## EIP communication protocol process input data

Byte	Function description								
	Function description	Bit7	Bit6	Bit5	Bit4	Bit3	Bit2	Bit1	Bit0
0	Standard IO input 0=no signal 1=There is signal	Port7 Pin4	Port6 Pin4	Port5 Pin4	Port4 Pin4	Port3 Pin4	Port2 Pin4	Port1 Pin4	Port0 Pin4
1	Standard IO input 0=no signal 1=There is signal	Port7 Pin2	Port6 Pin2	Port5 Pin2	Port4 Pin2	Port3 Pin2	Port2 Pin2	Port1 Pin2	Port0 Pin2
2	Short circuit detection Pin4 short circuit 0=no short circuit 1=There is a short circuit	-	-	-	-	Port3 Pin4	Port2 Pin4	Port1 Pin4	Port0 Pin4
3	Short circuit detection (Pin2 short circuit) 0=no signal 1=There is signal	-	-	-	-	Port3 Pin2	Port2 Pin2	Port1 Pin2	Port0 Pin2
4	Short circuit detection (Pin1 short circuit) 0=no signal 1=There is signal	Port7 Pin1	Port6 Pin1	Port5 Pin1	Port4 Pin1	Port3 Pin1	Port2 Pin1	Port1 Pin1	Port0 Pin1
5	IO-Link communication status 0=not connected 1=Connected	Port7	Port6	Port5	Port4	Port3	Port2	Port1	Port0

6	IO-Link PD is valid 0=disabled 1=enable	Port7	Port6	Port5	Port4	Port3	Port2	Port1	Port0
7	Module status	-	-	-	Us Overvo ltage	Ua Overvo ltage	Overhe at	Us Under voltage	Ua Under voltage
8-9	Reserve								
10-41	Port 0 process input data								
42-73	Port 1 process input data								
74-105	Port 2 process input data								
106-137	Port 3 process input data								
138-169	Port 4 process input data								
170-201	Port 5 process input data								
202-233	Port 6 process input data								
234-265	Port 7 process input data								

## EIP communication protocol configuration data

Variable	Function description									
	Function description	Bit7	Bit6	Bit5	Bit4	Bit3	Bit2	Bit1	Bit0	
Word	Pin4 Function 00=Normally open input 01=Normally closed input 10=output 11=IO-Link	Port3		Port2		Port1		Port0		
		Bit15	Bit14	Bit13	Bit12	Bit11	Bit10	Bit9	Bit8	
		Port7 (invalid configuration 10=output)		Port6 (invalid configuration 10=output)		Port5 (invalid configuration 10=output)		Port4 (invalid configuration 10=output)		
		Bit7	Bit6	Bit5	Bit4	Bit3	Bit2	Bit1	Bit0	
Word	Pin2 Function 00=Normally open input 01=Normally closed input 10=output	Port3		Port2		Port1		Port0		
		Bit15	Bit14	Bit13	Bit12	Bit11	Bit10	Bit9	Bit8	
		Port7 (invalid configuration 10=output)		Port6 (invalid configuration 10=output)		Port5 (invalid configuration 10=output)		Port4 (invalid configuration 10=output)		
		Bit7	Bit6	Bit5	Bit4	Bit3	Bit2	Bit1	Bit0	
Word	Pin4 SafeState 00 = remain at 0 01 = remain at 1 10 = keep the last value	Port3		Port2		Port1		Port0		
		Bit15	Bit14	Bit13	Bit12	Bit11	Bit10	Bit9	Bit8	
		Port7		Port6		Port5		Port4		
		Bit7	Bit6	Bit5	Bit4	Bit3	Bit2	Bit1	Bit0	
Word	Pin2 SafeState 00 = remain at 0 01 = remain at 1	Port3		Port2		Port1		Port0		
		Bit15	Bit14	Bit13	Bit12	Bit11	Bit10	Bit9	Bit8	
		Bit7	Bit6	Bit5	Bit4	Bit3	Bit2	Bit1	Bit0	

	10 = keep the last value	Port7	Port6	Port5	Port4
Byte	Port0 configuration*	( 1byte ) IOLink CycleTime ( 1byte ) Validation Type ( 2bytes ) Vendor ID1~ID2 ( 3bytes ) Device ID1~ID3 ( 16bytes ) Serial Number1~16 ( 1byte ) Parameter Server			
Byte	Port1 configuration*	(Same as above)			
Byte	Port2 configuration*	(Same as above)			
Byte	Port3 configuration*	(Same as above)			
Byte	Port4 configuration*	(Same as above)			
Byte	Port5 configuration*	(Same as above)			
Byte	Port6 configuration*	(Same as above)			
Byte	Port7 configuration*	(Same as above)			

Port configuration parameter description:

A. (1byte) IO-Link CycleTime cycle time setting:

This parameter can be used for IO-Link communication speed. Using multipliers and time base calculations, the IO-Link cycle time can be increased.

The time base is described in the table below. The multiplier is entered in decimal form from 0...63.

Bit								Description
7	6	5	4	3	2	1	0	
Time base		Multiplier						Bit 0 to 5: Multiplier These bits contain a 6-bit multiplier for the calculation of MasterCycleTime or MinCycleTime. Permissible values for the multiplier are 0 to 63. Bit 6 to 7: Time Base These bits specify the time base for the calculation of MasterCycleTime or WincvcleTime.

Possible values for MasterCycleTime and MiniCycleTime

Time base encoding	Time base value	Calculation	Cycle time
00	0.1ms	Multiplier x time base	0.4 ms to 6.3 m
01	0.4ms	6.d ms + multppler x time base	6.4 ms to 31.6 ms
10	1.6ms	32,0 ms + multiplier x time base	32.0 ms to 132.8 ms
11	Resarved	Resarved	Resarved
NOTE: The value 0.4 results from the minimum possible transmission time according to A.3.7			

B. (1byte) Validation Type verification type setting:

(Value=0) No verification: Verification is disabled and every device will be accepted.

(Value = 1) Compatibility: Compare the manufacturer ID/device ID with the IO-Link device data.

(Value=2) Identity: Compares Manufacturer ID/Device ID/Serial Number with IO-Link device data. IO-Link communication only starts when there is a match.

C. (2bytes) Vendor ID1~ID2 manufacturer ID

D. (3bytes) Device ID1~ID3 device ID

E. (16bytes) Serial Number1~16 serial number

F. (1byte) Parameter Server parameter server (reserved)

## CCIEBS communication protocol process output data

Byte	Function description								
	Function description	Bit7	Bit6	Bit5	Bit4	Bit3	Bit2	Bit1	Bit0
RY (256Bit)	Standard IO output	Port7 Pin4	Port6 Pin4	Port5 Pin4	Port4 Pin4	Port3 Pin4	Port2 Pin4	Port1 Pin4	Port0 Pin4
	0=off 1=on	Port7 Pin2	Port6 Pin2	Port5 Pin2	Port4 Pin2	Port3 Pin2	Port2 Pin2	Port1 Pin2	Port0 Pin2
	(The rest of the points are reserved)								
RWW (256Byte)	Port 0 process output data								
	Port 1 process output data								
	Port 2 process output data								
	Port 3 process output data								
	Port 4 process output data								
	Port 5 process output data								
	Port 6 process output data								
	Port 7 process output data								

# CCIEBS communication protocol process input data

Byte	Function description								
	Function description	Bit7	Bit6	Bit5	Bit4	Bit3	Bit2	Bit1	Bit0
RX (256Bit)	Standard IO input 0=No signal 1=There is signal	Port7 Pin4	Port6 Pin4	Port5 Pin4	Port4 Pin4	Port3 Pin4	Port2 Pin4	Port1 Pin4	Port0 Pin4
	Standard IO input 0=No signal 1=There is signal	Port7 Pin2	Port6 Pin2	Port5 Pin2	Port4 Pin2	Port3 Pin2	Port2 Pin2	Port1 Pin2	Port0 Pin2
	Short circuit detection (Pin2/4 short circuit) 0=no short circuit 1=There is a short circuit	Port7 Pin4	Port6 Pin4	Port5 Pin4	Port4 Pin4	Port3 Pin4	Port2 Pin4	Port1 Pin4	Port0 Pin4
	Short circuit detection (Pin2/4 short circuit) 0=no signal 1=There is signal	Port7 Pin2	Port6 Pin2	Port5 Pin2	Port4 Pin2	Port3 Pin2	Port2 Pin2	Port1 Pin2	Port0 Pin2
	Short circuit detection (Pin1 short circuit) 0=no signal 1=There is signal	Port7 Pin1	Port6 Pin1	Port5 Pin1	Port4 Pin1	Port3 Pin1	Port2 Pin1	Port1 Pin1	Port0 Pin1
	IO-Link communication status 0=not connected 1=Connected	Port7	Port6	Port5	Port4	Port3	Port2	Port1	Port0
	IO-Link PD valid 0=disabled 1=enable	Port7	Port6	Port5	Port4	Port3	Port2	Port1	Port0
	Module status	-	-	-	Us Overv oltage	Ua Overv oltage	Overh eat	Us Under voltage	Ua Under voltage
(The rest of the points are reserved)									
RWR (256Byte)	Port 0 process input data								
	Port 1 process input data								
	Port 2 process input data								
	Port 3 process input data								
	Port 4 process input data								
	Port 5 process input data								

	Port 6 process input data
	Port 7 process input data

Note:

1. Please set the CCIEBS master port function in the FAS IOLink Tool software.
2. Points of 64 occupy 1 station, and the slave station connected to each port uses 4 words of points.
3. Points 128 occupy 2 stations, and the slave station connected to each port uses 8 words of points.
4. Points 192 occupy 3 stations, and the slave station connected to each port uses 12 words.
5. Points 256 occupy 4 stations, and the slave station connected to each port uses 16 words of points.
6. Please refer to Chapter 5.1.3 for point setting.

### 3.3 PLC integration tutorial

(The module communication protocol should be set before configuring the module, see 5.1.1 for details)

#### 3.3.1 Siemens S7-1200 Portal Integration (PN)

##### 1. Install GSD file

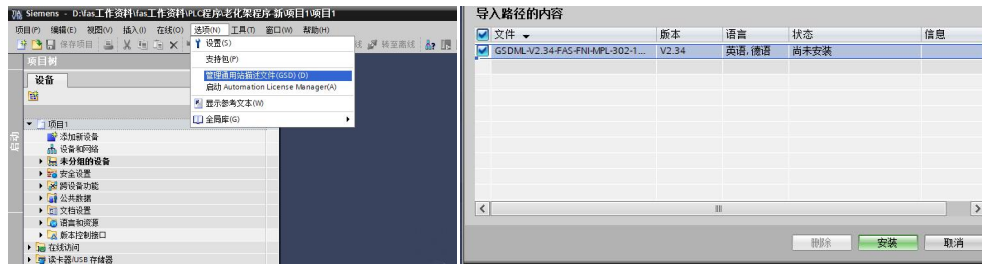

2. In PLC---Device Configuration---Network View---Hardware Catalog, select the module and drag it in, click "Unassigned", and select the PLC to be connected;

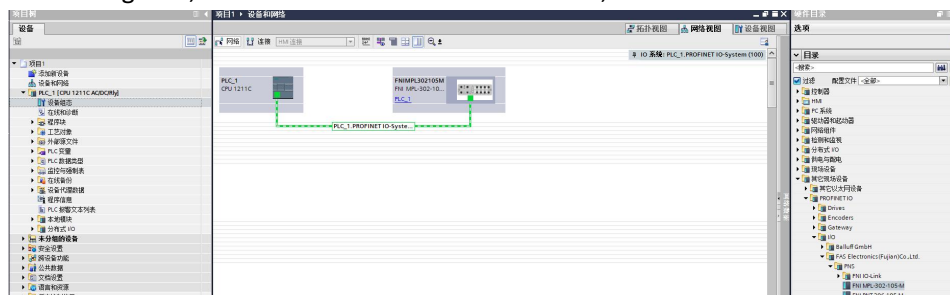

3. Double-click the module to enter the configuration.

- (1) Slot function configuration: Select the required data in the hardware catalog--Module and drag it into the slot in the device overview window;
- (2) Module port function configuration: Click the module icon, select "General", then click slot 1 to configure the port function

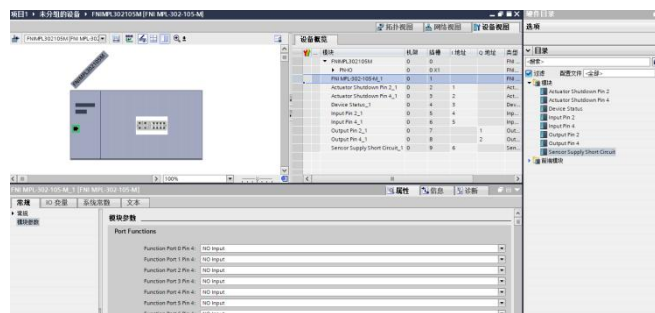



(3)Module function configuration: Click the module icon, select "General", then click slot 0 to configure the module function

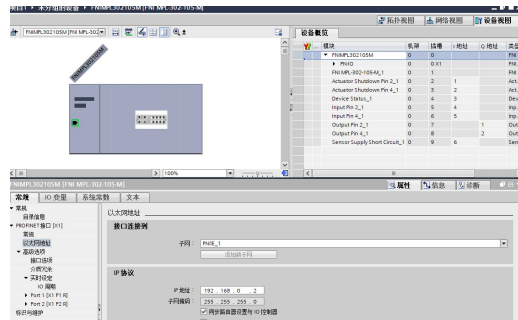

(4)After the configuration is completed, click Download in the configuration view.

4. Assign module PN name: PLC switches to online state, select "Ungrouped Device"---Click the module name----Select Online and Diagnosis---Function----Assign PROFINET device name--  
--Select the module to be assigned in the list (should be selected based on the physical MAC)  
---Click "Assign Name" to complete the configuration!

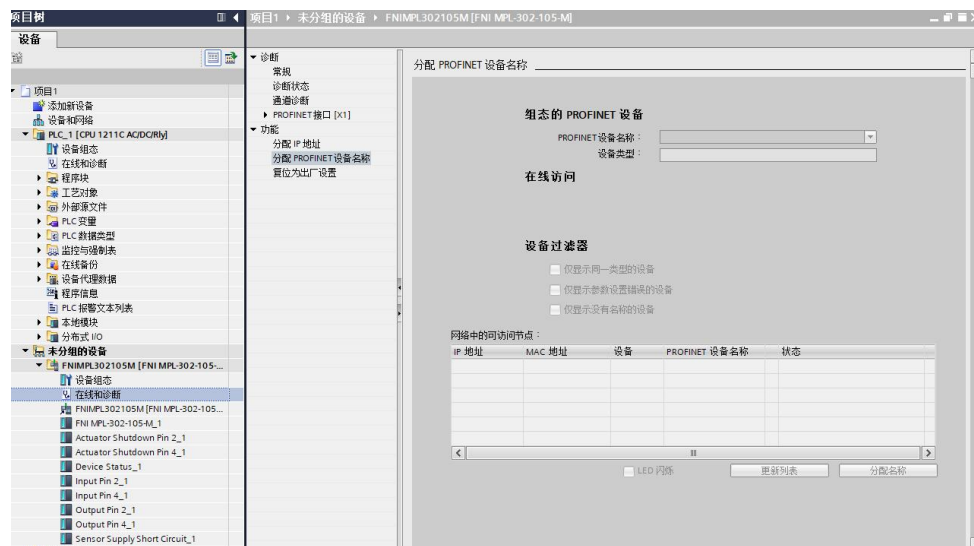

### 3.3.2 Omron NX1P2 Sysmac Studio Integrated (EIP)

1. Install the EDS file: Tools---ETHERNET/IP connection settings---double-click the PLC in the window---right-click the blank space in the toolbox on the right and select "Show EDS Library", click "Install" in the pop-up window, and select EDS file installation

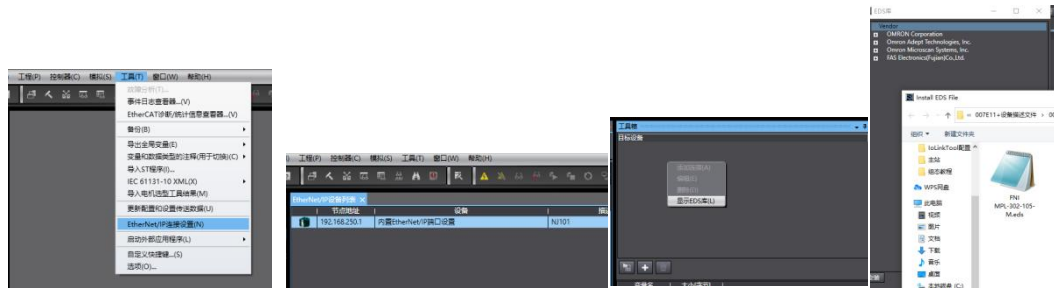

2. Create a module: Click "+" in the toolbox window, fill in the module IP address, model name, and version, click "Add" below, and the module creation is completed;

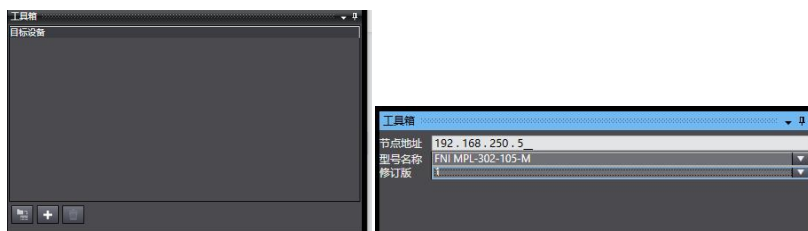

3. Configure the module: right-click the module - select "Edit" - configure the corresponding values in the parameters according to actual needs and click OK after completion.

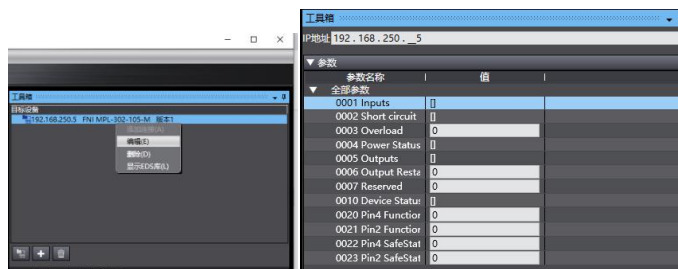

4. Create variable association:

- (1) Programming--Data--Global variables create two arrays, output 262 bytes and input 266 bytes. The corresponding input and output should be configured in the network exposure;

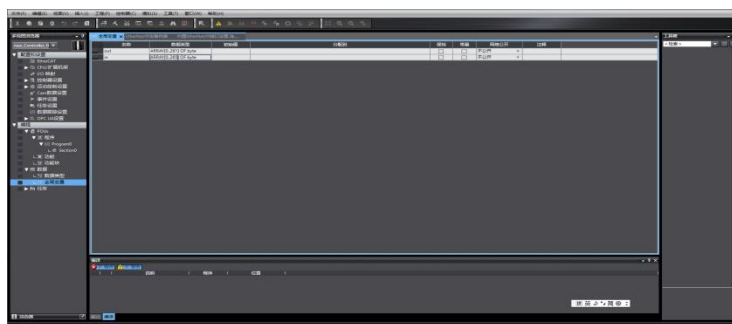

- (2) In the built-in ETHERNET/IP port setting window--select the first icon (label) on the left---click "Register All"

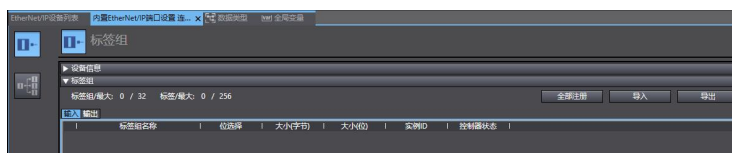

(3) In the built-in ETHERNET/IP port setting window--select the second icon on the left (connection)---click "+", select the previously configured module for the target device, select EXCLUSIVE Owner for the IO type, and select the corresponding For input and output, the target variable must be filled in 101,100; then select the corresponding starting variable and go online after completion. Select "Transfer to controller" and the configuration is complete!

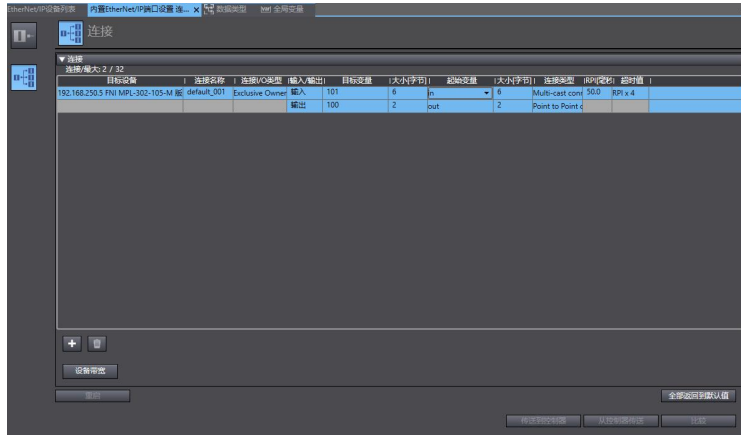

### 3.3.4 Mitsubishi FX5U Work2 integrated (CCIEBS)

1. Install the CCSP file: First open GX WORKS 3-Tools-Configuration File Management-Login-CSPP file (the project must be closed to import the file)

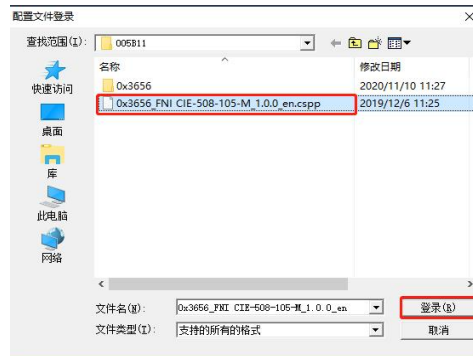

2. Click Project on the left - Parameters - FX5UCPU - Module parameters - Ethernet port, Basic settings - Self-node settings. Set own node IP

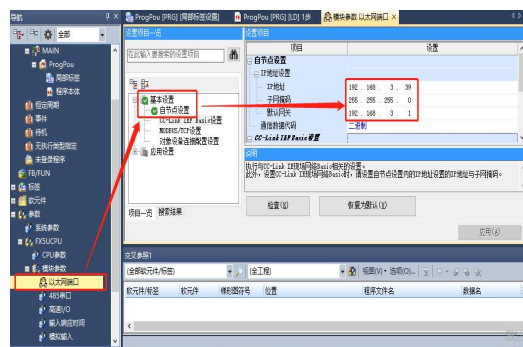

3. Click CC-Link IEF Basic settings - select whether to use CC-Link IEF Basic - click Use

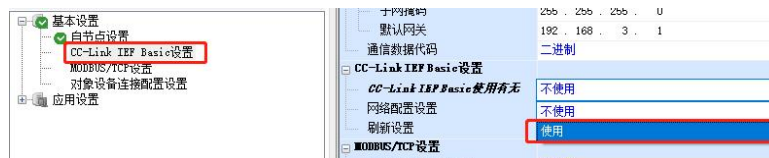

4. Click CC-Link IEF Basic settings-select network configuration settings-detailed settings;



5. Automatic detection of connected devices - occupies 4 stations, IP address is set using DIP switch - reflects the setting and closes



6. To refresh the target, select the specified device-software name M-assign the device address-application, and the configuration is completed!

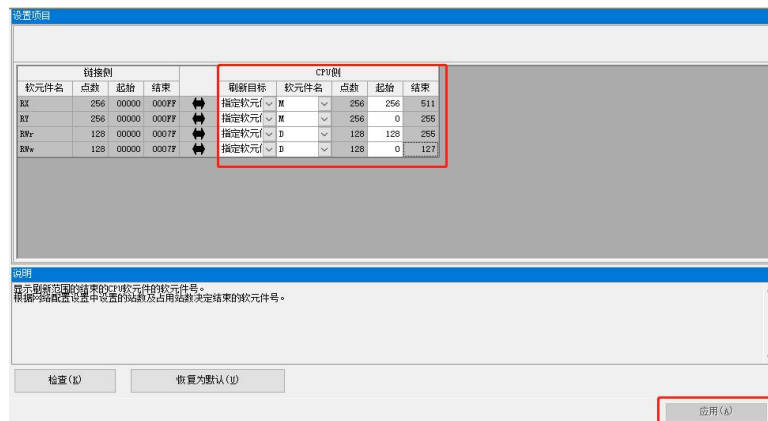

# 4. Appendix

## 4.1. Materials included

- FNI MPL contains the following parts
- I/O-Block
- 4 blind plugs M12
- Ground bus
- Thread M4x6
- 20 tags

## 4.2. Order code

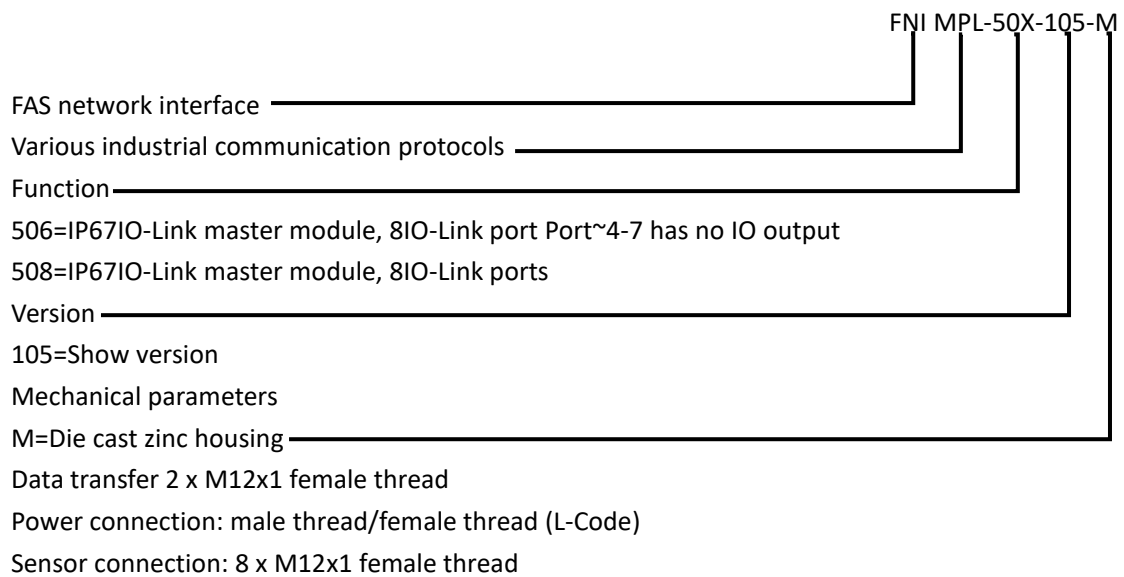

## 4.3 Ordering information

Product ordering code	Ordering code
FNI MPL-506-105-M	007B31

High quality products · Sincere service



[ Technical support ]



[ Official website ]



Telephone : 0591-22991876

Technical support : +86 13306936805

Official website: [www.faselec.com](http://www.faselec.com)

Business support : +86 19905006938

Address: Room 009, A1, Building 1, National University Science and Technology  
Park Science and Technology Innovation Center, No. 6 Qiuyang East Road,  
Shangjie Town, Minhou County, Fujian Province.